

DIGITAL CONTROL
OF
A THYRISTOR-DRIVEN D-C MOTOR
BY

Elsayed H. El-Konyaly, A. Abdul-Magid Hassan and
Reda M.K. El-Dewieny*

ABSTRACT

Phase control represents an effective means of controlling the average power delivered to a load. The principle of phase control is used to control the speed, current and torque of a separately excited D-C motor. The interference between the operator and the control circuit is provided by a set of coded instructions through a minicomputer software. The idea of decentralized control is implemented. The computer program (written in Assembly Language) as well as the wiring diagram are included.

1. INTRODUCTION

The growth of electric drives has closely paralleled the growth of automation in industry. Electric drive systems provide a convenient means for controlling the operation of industrial machinery. The high reliability and great versatility of these systems is a direct interpretation for their wide spread applications¹.

The use of computers instead of controller units in electric drives represents a major advance in the philosophy of control. Computer control have recently been enhanced by the tremendous achievements in manufacturing integrated circuits². The major contribution of computers in control means a change from purely hard-ware based control to a soft-ware based systems. This actually brings out two main advantages:

- 1) An increase in control flexibility, and
- 2) A reduction and simplification in hard-ware circuits.

In other words, the modification of any drive system to suit specific needs simply means reprogramming instead of rewiring.

Another advantages of computer control is that, the closed-loop feedback device is an encoder which makes the control loop relatively simple.

* The authors are lecturers at the Department of Electrical Engineering, Faculty of Engineering, University of El-Mansoura.

Fig. (1) illustrates the basic computer control scheme using microprocessor. Because of the introduction of sampling and the use of microprocessor in this type of system, lower loop gains had to be used for the position servo loop.

The advent of microprocessors and their flexible programmability have rapidly enhanced the decentralized control of electric drives. The application of microprocessors in control has opened a wide range of opportunities for improved control through strategies using the logical and computational capacity of the ever-developed microprocessors. They provide solutions to problems encountered with the early computer control systems such as data transmission, timing problems and initial investments³. In other words, they provide solution to the problems of both costs and complexity. In addition, recent generation of microprocessors operates at sufficient speeds which match the requirements of practical control systems and increase the flexibility of digital control.

This paper is intended to implement the ideas cited above to the control of a variable speed, separately excited D-C motors. The variable speed have been obtained by the use of "phase control of a thyristor bridge"⁴. Before we proceed, the principle of phase control will be summarized.

2. PRINCIPLE OF PHASE CONTROL:

Phase control is the process of rapid on-off switching which connects an a.c. supply to a load for a controlled fraction of each cycle. The process is achieved using solid-state elements and the arrangement is known as "phase-controlled converter".

Phase-controlled converters consist, basically, of a rectifier circuit arrangement in which some or all of the rectifier devices are silicon-controlled rectifiers (SCR's).

Phase-control techniques have the following advantages:

- 1) The absence of wear out mechanism which is present in mechanical switches,
- 2) High speed performance,
- 3) The circuit is usually simple and less expensive, and
- 4) The circuit is inherently proportional control.

There are many forms of phase control with SCR's⁴. Fig.(2) shows a simplified scheme of a full wave bridge, together with the voltage curve for a given delay angle α , for a resistive load. It is obvious that the increase of α will reduce the power delivered to the load and in case of motor load, will decrease the speed. A starting resistor, in this case, is no longer necessary because the average motor voltage is zero at $\alpha = 180^\circ$, and can be increased to its maximum value at $\alpha = 0^\circ$.

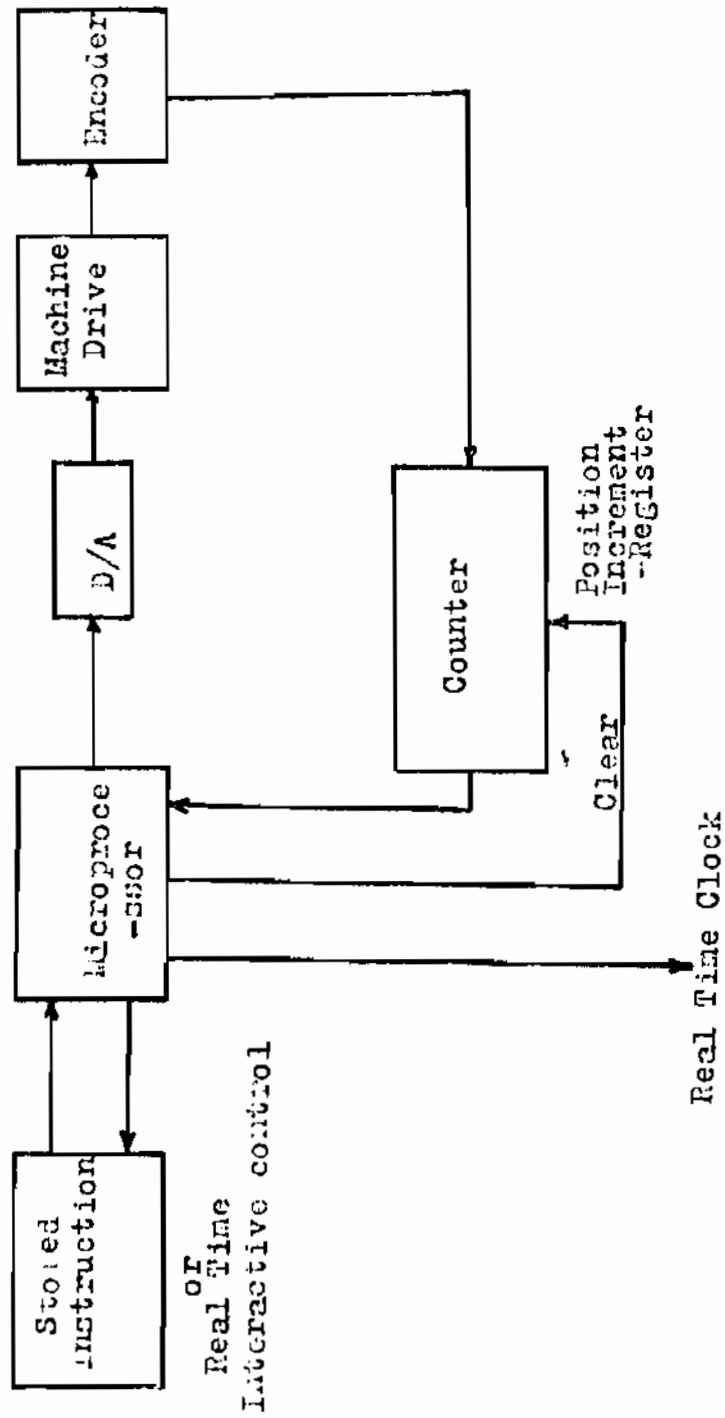

Fig. 1: Basic Computer Control Scheme Using Microprocessor

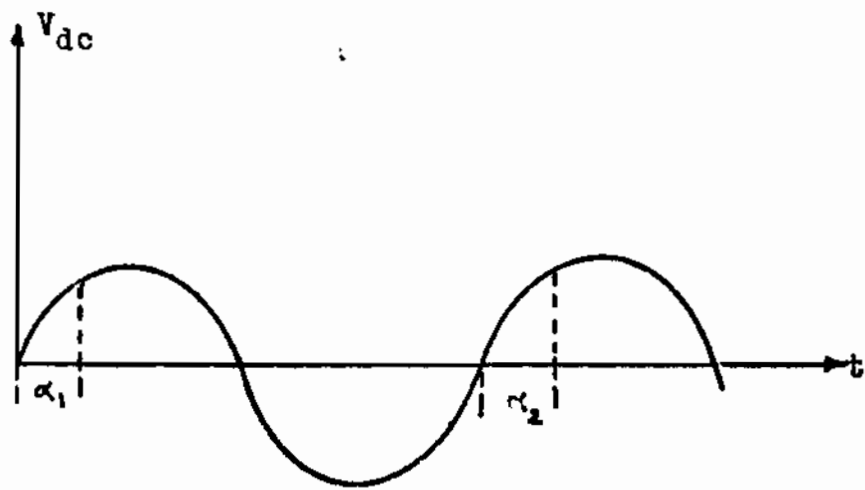
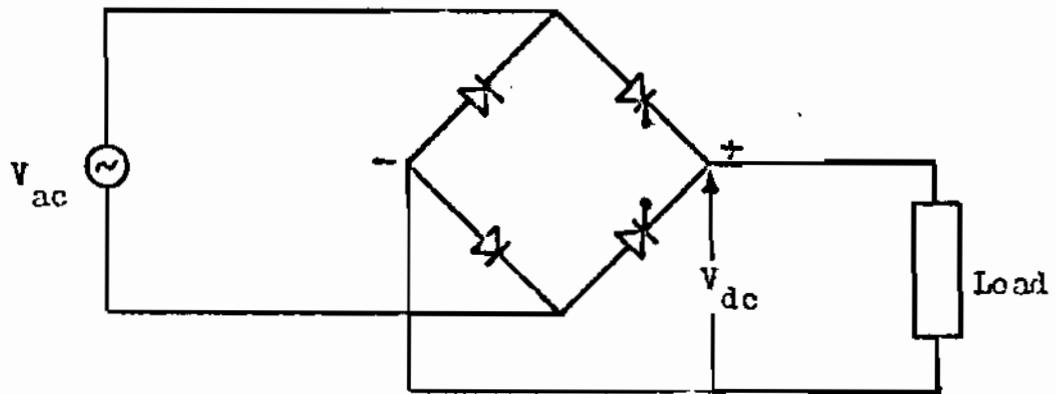

Fig. 2.

3. Description of the Wiring Diagram:

Fig. (3) represents the basic components as well as the necessary interface linking the computer to the circuit of the D-C motor. A full wave asymmetrical bridge constitutes the power converter. The triggering circuit for the SCR's consists of a combination of a light emitting diode (LED) together with a light activated SCR (LASCR). This combination provides circuit isolation between the control circuit and the power circuit. When the control circuit is activated, a current flows through the LED which turns on the LASCR and the control pulse is amplified enough to turn on the main SCR. The free wheeling diode carries the inductive motor current when the SCR's are turned off.

4. Digital Control System for the Full Wave Bridge:

The program of the control system is illustrated in the flow chart of Fig. (4). An A/D conversion unit samples the line voltage and also the adjustable reference voltage. The relationship between the reference voltage and the delay angle is worked out in the program in such a way that zero reference voltage corresponds to 180 degree delay angle and a 10-V reference voltage corresponds to zero degree delay angle. Fig.(5) shows the relationship between the reference voltage and the delay angle. Such a dependency of α from V_{ref} causes the output voltage of the bridge to increase with the value of the reference voltage.

The program, a list of which is given at the end of this paper, determines the positive and negative zero crossings of the line voltage by testing the sign of the two consecutive line samples (Fig. 6). After each zero crossover, the delay angle α is calculated from the sample of the given reference voltage. A digital clock counts down in time until the desired value of α is reached. Then the clock counts down again for a time of 3.3 ms, which is equivalent to a 60-degree pulse of a 50-Hz waveform. During the 3.3 ms period, a positive pulse is generated in the computer output device. If the delay angle α is more than 120 degrees, the pulse width is decreased so that the pulses always terminate at the next zero crossing.

The generated pulse turns on a transistor in the computer which drives a current through LASCR. There of the main SCR is activated.

5. CONCLUSIONS

Decentralized control represents a major advance in control philosophy. This paper has implemented this idea for controlling a D-C separately excited motor. The speed, current and torque are controlled through a set of coded instructions provided by a mini-computer system. The control scheme is presented in compact,

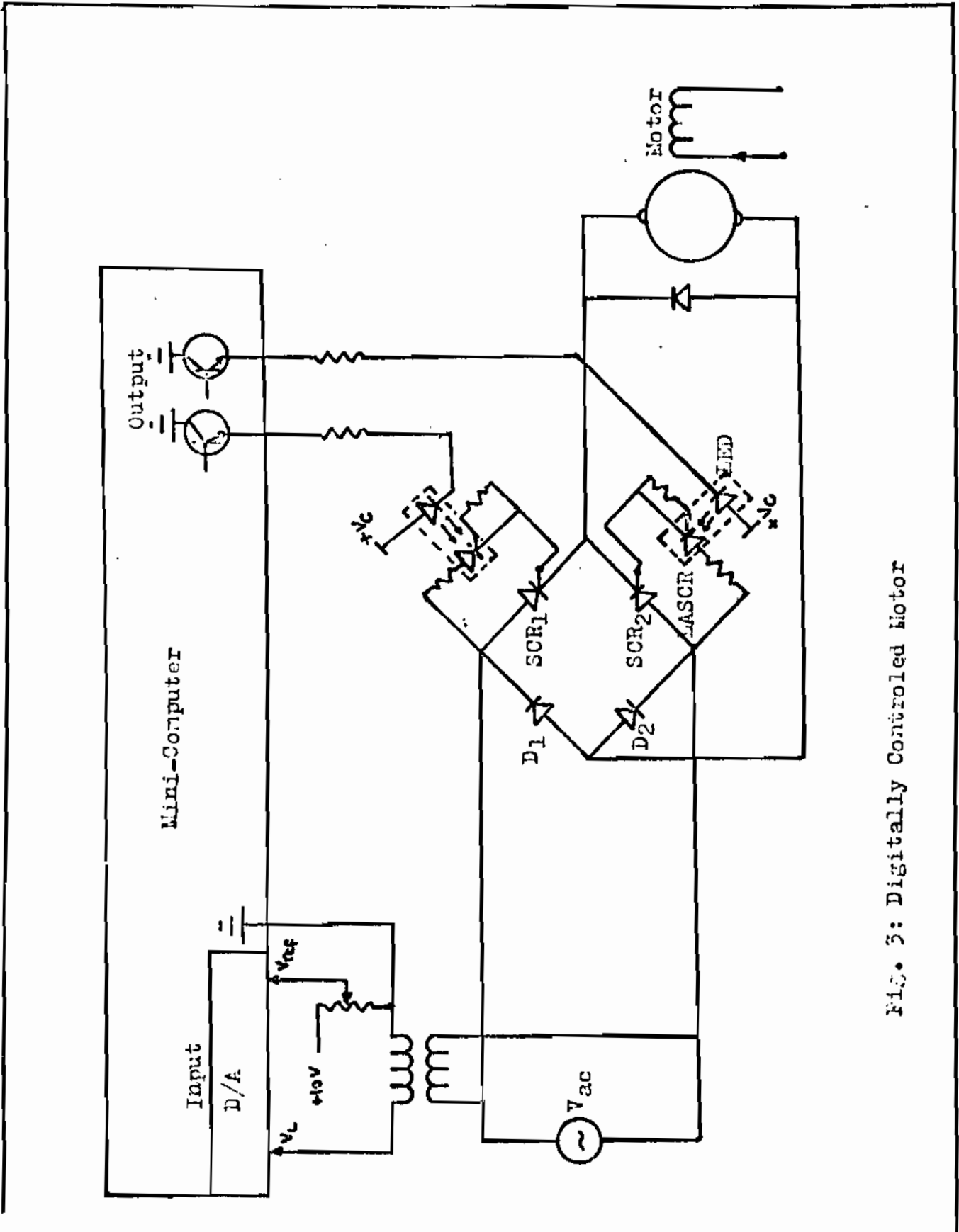

FIG. 3: Digitally Controlled Motor

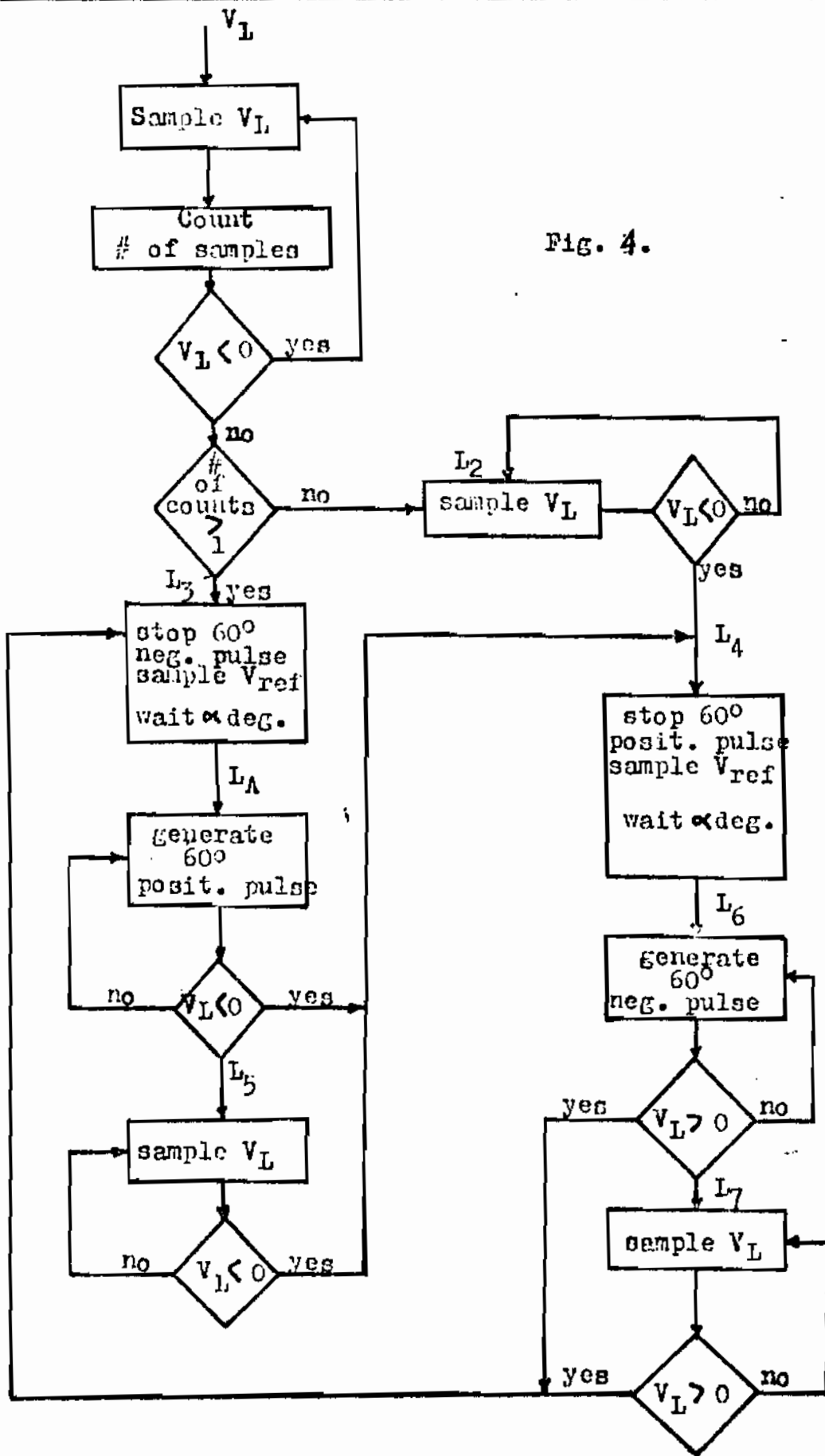

Fig. 4.

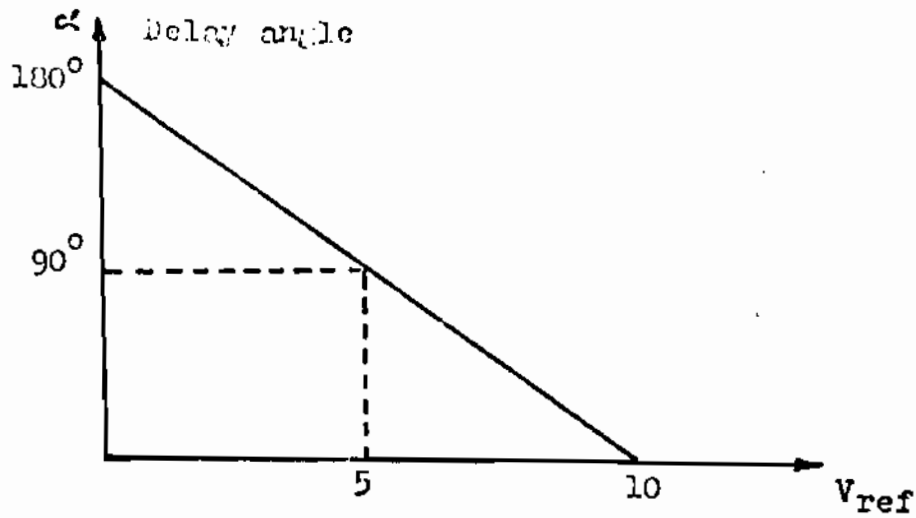

Fig.5: Relation between V_{ref} and delay angle

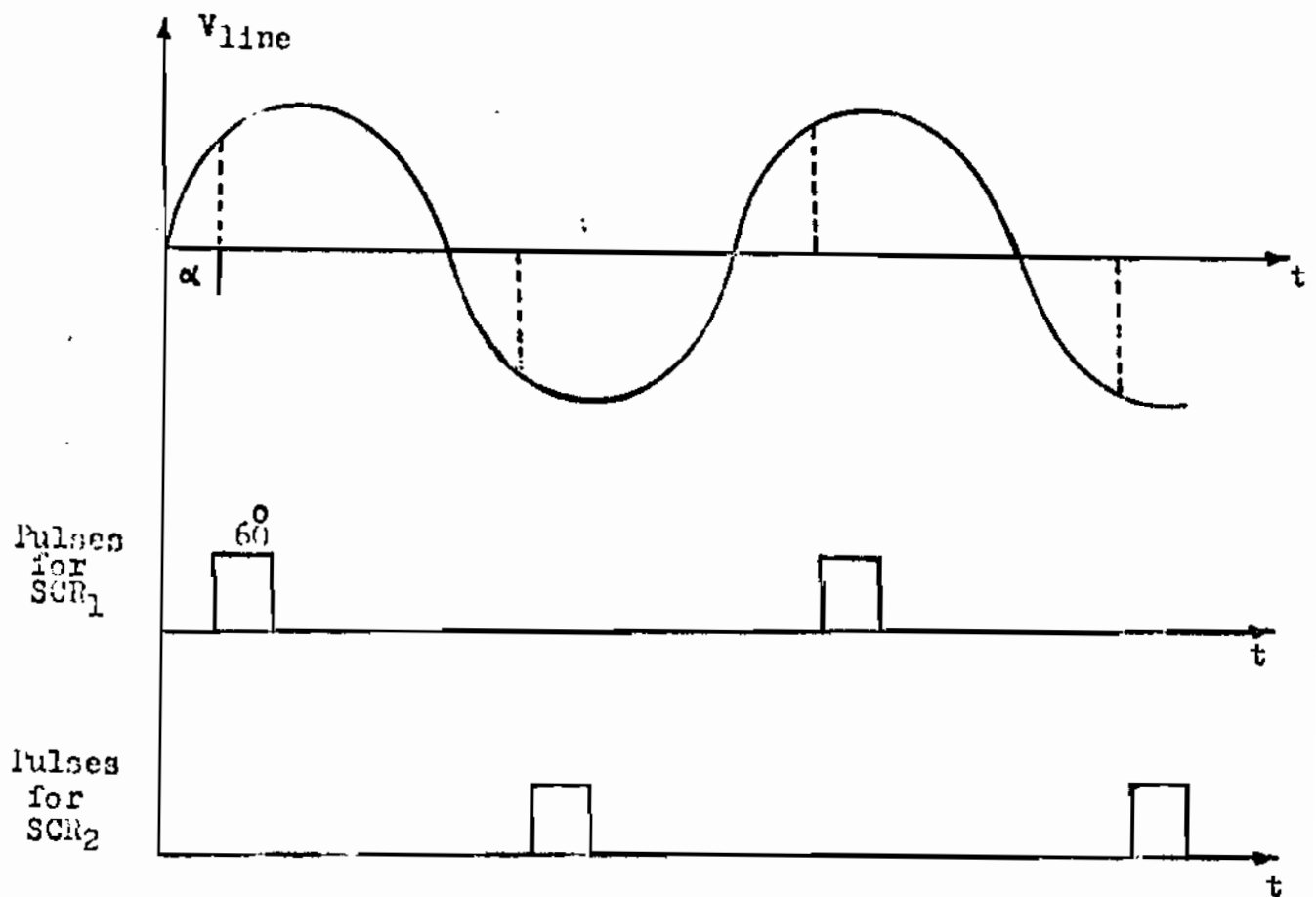

Fig.6: Line voltage samples

26. Mansoura Bulletin June 1978.

efficient and flexible way. The introduction of soft-ware control introduces a smooth transition from one operating point to another excessive wear on the moving parts.

6. REFERENCES:

1. R. Schiemen et. al., "Solid Stats Control of Electric Devices", Proc. IEEE, Dec. 1974, pp 1643-1660.
2. Technology 78 "An Application Review", IEEE Spectrum, Jan. 1978.
3. "Applying Microprocessors", Book, McGraw-Hill, 1976, Edited by L. Altman and S. Scrupski.
4. "SCR Manual" General Electric, U.S.A., 1972.

Computer Program for
D-C motor control

ADCS = 176770		L2:	MOV	#1001,ADCS
ADDB = 176772			TSTB	ADCS
DR110 = 167772			BPL	.-4
CCSR = 172540			MOV	ADDB,R1
CCSB = 172542			TST	R1
PERK = 164000			BGT	L2
MQ = 177304			BR	L4
R0 = %0		L3:	CLR	PERK
R1 = %1			CLR	DR110
R2 = %2			MOV	#0,CCSR
R3 = %3			MOV	#1401,ADCS;
R4 = %4				A/D Sampling of REF
R5 = %5				V ON' CH#3
	CLR	R0	TSTB	ADCS
	CLR	R1	BPL	.-4
	CLR	R2	MOV	#1777,R3
	CLR	R3	SUB	ADDB,R3
	CLR	R4	DIVID:	MOV
	CLR	R5	MOV	#MQ,R5
			MOV	R3,(5)
Start:	CLR	COUNT	MOV	#0,-(5)
	CLR	PERK	MOV	#14,-(5)
	CLR	DR110	TST	(5)+
L1 :	MOV	#1001,ADCS;	TST	(5)+
		A/D Sampling of	MOV	(5),CCSB
		LINE V ON' CH#2	MOV	#3,CCSR
	INC	COUNT		Clock STARTS TO
	TSTB	ADCS		SET FIRING ANGLE
	BPL	.-4	TSTB	CCSP
	MOV	ADDB,R1	BPL	.-4
	TST	R1	CLR	R4; GENERATION OF
	BLT	L1		60 DEGREE +ve PULSES
	CMP	COUNT,#1	LA:	MOV
	BGT	L3	MOV	#2,CCSB
				#3,CCSR

	MOV	#1001,ADCS		MOV	#3,CCSR
	TSTB	ADCS		TSTB	CCSP
	BPL	.-4		BPL	.-4
	MOV	ADDB,R1		CLR	R4; GENERATION
	TST	R1			of 60 Degreee
	BMI/	LA			-ve pulsee
	TSTB	CCSR	L6:	MOV	#2,CCSB
	BPL	.-4		MOV	#3,CCSR
	MOV	#1,PERK		MOV	#1001,ADCS
	MOV	PERK,DR110		TSTB	ADCS
	INC	R4		BPL	.-4
	CMP	R4,#14		MOV	ADDB,R1
	BLT	LA		TST	R1
L5:	CLR	PERK		BPL	L10
	CLR	DR110		BMI	L11
	MOV	#1001,ADCS	L10	JMP	L3
	TSTB	ADCS	L11	TSTB	CCSR
	BPL	.-4		BPL	.-4
	MOV	ADDB,R1		MOV	#2,PERK
	TST	R1		MOV	PERK,DR110
	BGT	L5		INC	R4
L4:	CLR	PERK		CMP	R4,#14
	CLR	DR110		BLT	L6
	MOV	#0,CCSR	L7:	CLR	PERK
	MOV	#1401,ADCS;		CLR	DR110
		A/D Sampling of		MOV	#1001,ADCS
		REF V ON' CH#3		TSTB	ADCS
	TSTB	ADCS		BPL	.-4
	BPL	.-4		MOV	ADDB,R1
	MCV	#1777,R3		TST	R1
	SUB	ADDB,R3		BMI	L7
TEILN:	MOV	#MQ,R5		JMP	L3
	MOV	R3,(5)	OUT:	EMT	60
	MOV	#0,-(5)	COUNT:	.WORD 0	
	MOV	#14,-(5)	BUFF:	. = .+4000	
	TST	(5)+		. END START	
	TST	(5)+			
	MOV	(5),CCSB			