

# Development of a Locally Vacuum Vegetable Seeder for Nursery Trays

EL-Ghobashy\*, H. M.; T. H. A. Mohamed\*; A. M. EL-Ashker\* and Y. A. Shabaan\*

\* Agric. Res. Center, Dokki, Egypt



## ABSTRACT

A continuous feeding mechanism for precision vacuum trays seeder was developed and fabricated from locally materials for seeding single seed in the trays. The developed seeder was evaluated under two trays types of 84 and 209 cells, four different suction pressure levels (0.5, 1, 1.5 and 2 kPa) & (0.3, 0.6, 0.9 and 1.2 kPa) and four different hole size diameters of seed plate (1.2, 1.4, 1.6, 1.8 mm) & (0.4, 0.6, 0.8, 1.0 mm) for cucumber and cabbage seeds respectively. The seeding unit comprises of different parts whose functions are coordinated to place one seed into the center of tray cells in certain position. Trays were placed one by one without any gap in between for continuous seeding. Seeded trays were collected from the other end of the machine. The performance of the seeder was evaluated using the singulation efficiency, seed utilization efficiency, seeding efficiency, the seeder productivity, the specific energy requirement and the seeding operation costs. It was found that the trays seeder productivity was 240 trays h<sup>-1</sup> (20160 and 50160 cells h<sup>-1</sup> for cucumber and cabbage seeds respectively). The proper seeder results for seeding singles seed in trays (90.5 and 70.4% ) were obtained with the dual interaction effect between the suction pressure at 1.5 and 0.9 kPa and hole diameter at 1.6 and 0.8 mm for cucumber and cabbage seeds respectively, when the consumed specific energy of 4.16×10<sup>-3</sup> kWh tray<sup>-1</sup>. The precision trays seeder reduced the estimated cost by 5 to 12 times than the seeding trays manually for cucumber and cabbage respectively.

## INTRODUCTION

A survey of some commercial nurseries revealed that the peak season demand of vegetable seedlings from a nursery of average size was about 0.1 million seedlings per day, but this was expected to double in the near future (Gaikwad and Sirohi 2008). A major portion of the area under vegetable cultivation is now sown with hybrid seeds, which are costly but give higher yields and quality production. The majority (83%) of vegetable transplants are from three crops namely, tomatoes (45%), peppers (28%) and cabbage (10%) (Vavrina and Summerhill, 1992).

In view of the high cost of such seeds, it is necessary to achieve maximum germination and disease-free seedlings for transplanting in open fields. The raising of seedlings in trays (or pro-trays) is one such technology that achieves this requirement. The tray is filled with a soil-less substrate, consisting of cocopeat and vermiculite and one seed is manually placed in each cell. However, placing a single seed in each cell is the most labor-intensive operation. About eight man-hours are required to sow 100 trays for raising 9800 seedlings (Gaikwad and Sirohi 2008).

The seed sowing in tray can be seeding by 2 methods. 1: Hand sowing seeds usually is used to prepare trays in small scale farming, but it is inexpensive to operate this way. 2: mechanically sowing: It is normally used for preparing trays in middle or big scale farming. The costs of imported seeding machine are so expensive and the complexity of machine in working system is the main problem for maintenance (Sriwongras and Dostal, 2013). They added that the seeder for plug tray was initially tested in order to sow the papaya seed into the plug tray of 60 cells. Resulting indicated that their efficiency for releasing seeds on plug tray has a value of 79%. For operation time, the sowing by the seeder was 7.88 times quicker than that the sowing by human-hand.

The metering of the seed flow, has two aspects, the first is metering rate, refers to the number of seeds that released from the hopper per unit time. The second is that, single-seed must be seeding in precision planters to allow placement of seeds at uniform spacing in each row (Ismail, 2004). In this respect (Ismail *et al.*, 2014) reported that precision farming systems using air pressure positive or negative is facing many problems during application, the most important imbalance resulting from the pressure change during the process of agriculture, as well as with regard to the possibility of keeping seeds through holes feeder. These problems are complicated attempts at agriculture in seeding trays to need of high accuracy during planting, where you must maintain a certain number of catching seeds with pinpoint precision landing in the definite area and not have any unit of the content of the seeds in order to ensure growth replication seedlings

Gaikwad and Sirohi (2008) fabricated and tested the performance for sowing capsicum and tomato seeds in plug trays. The seeder worked satisfactorily at suction pressures of 4.91 and 3.92 kPa and nozzle diameters of 0.46 and 0.49 mm to achieve more than 90% sowing single seed in the case of capsicum and tomato, respectively. The capacity of seeder, depending on the tray size used, ranged between 38,000 and 60,000 cells h<sup>-1</sup>. The total cost of sowing 1000 cells using a prototype precision plug seeder was found to be Rs. 1.56 (USD 0.034) which was only 15.27% of the estimated cost of manual sowing.

Hassan (2014) designed, constructed and tested a prototype for seeding tomatoes seeds in tray. The fundamental basic of the prototype was depending on using air vacuum to catch single seed from seed tank and put it inside tray cells using electrical control unit. Engineering parameters were evaluated by analyzing the relative relationships between the various parameters such as feeding device height "h, mm" of 0.0, 1.0, 2.0, 3.0 and 4.0 mm; four different levels of orifice positions "hb" of 1, 2, 3 and 4; four orifice diameters on seeding

tube "d" of 0.5, 0.75, 1.0 and 1.5mm and three air suction pressure "p" of 31.80, 33.44 and 85.10 mbar on seed catching, doubling and skipping seeds in tray cells. The results indicated that the best value of feeding device height that fulfill catching one seed per orifice was  $h = 2.2\text{mm}$  at suction tube orifice diameter of 0.5mm and air suction pressure of 33.44mbar. Increasing the orifice diameter to 0.75, 1.0 and 1.5 mm the best (h) were 2.9, 3.2 and 3.9mm respectively. At these operating parameters the results recorded no seeds skipping and low doubling.

Kim *et al.* (2003) developed a vacuum nozzle seeder for the automatic sowing of large seeds of fruit, vegetables and root stocks. They reported that the important operating factors for obtaining high seeding rates were typically nozzle diameter and extraction vacuum pressure. Hu *et al.* (2003) developed a magnetic precision seeder for plug seedlings, which picked up seeds coated with magnetic powder. The number of seeds picked by magnetic head as well as the seed singulation was controlled by adjusting magnetic field. Also, Zigmanov (1997) studied the efficiency of machine sowing of vegetable seeds into containers for 18 vegetable crops and concluded that the factors affecting the efficiency of sowing were the degree of vacuum, nozzle diameter, the method of inserting the nozzle into the vessel holding the seed, the shape of the seed as well as the degree of seed finishing, such as cleanliness, sizing, surface polishing and prilling. Zhang and Guo (2012) investigated seed-metering device using the movement simulation and module. According to the analysis results, the defaults of the feed device were showed that this device is simple and suitable for the seeding requirements of small grains.

Owing to the above view, the manual seeding for small seeds in cells-tray are tedious, labor intensive and costly. The precision seeders for nursery trays are not available in Egypt. High capacity imported seeders are not suitable for small sized nursery growers due to their high costs. So, the aim of this study is to develop; construct and test the performance of a low cost pneumatic tray type vegetable seeder for medium sized nursery production that takes care of the problems mentioned above. To assure accurately seed a single seed in tray cells and simultaneously sow one complete tray in one batch.

## MATERIALS AND METHODS

A developed precision vacuum trays seeder prototype is made of locally available materials to reduce the cost. Efforts were made to keep the mechanism and operation of the machine as simple as possible.

### Transplanting Trays:

In Egypt the foam trays are the most widespread for vegetable seeds transplanting. The dimensions of the all foam plug trays types are 673×393×60 mm for length, width and depth respectively. With regard to the cells number per tray, there are two different types of foam trays are used. The first type is composed of 209

cells (19 column ×11 row), each cell has drainage hole, square corner of 27×27 mm, V shape cell and it is using with small size seedlings. The second type is composed of 84 cells (12 column × 7 row) with square corners of 45×45 mm and it was using with large size seedlings.

### Operational Sequence of the Prototype:

As shown in Figs. 1 and 2 the trays are mechanically feeding from hopper (10) into position under the head seeder (14). The trays are vertically feeding into the hopper one by one over each other through side door. At the hopper base the fed trays are placed on a sliding wooden drawer (9) that is mounted on a horizontal reciprocating mechanism (8). During the backwards reciprocating motion is started to guide the drawer only without trays, the trays are dropped down to replace the drawer. Conversely, when the forward reciprocating motion is started, the drawer inversely moves to push one fallen tray to place it under the seeder zone. This occurs in every cycle of reciprocation, which previously specified when the proposed calibration.

The seeder is mounted above two stands (15) by a rotating shaft (18) and two ball bearings (20 mm ID). The seeder manually rotates on its axis and tilted at a desired angle to facilitate movement of seeds slowly towards the seed pickup position. The seeding unit comprises of different parts whose functions were coordinated to place one seed into the center of tray cells in certain position. Trays were placed one by one without any gap in between for continuous seeding. Seeded trays were collected from the out end of the machine.

### Prototype Description:

**The structures of the major components of the seeder are described as follows:**

**Trays feeding system:** The trays are feeding one by one into the hopper that was constructed from rectangular wooden strips (20 × 25 mm for thickness and width). The external hopper dimensions are 1000 × 730 × 430 mm for height, length and width respectively. Two rectangular openings with the same sizes (675 × 65mm) are provided at the hopper base. The first opening is used to allow of drawer reciprocating motion and the other is used to keep facilitate of only one tray delivery under the seeder zone.

**Seeding unit elements:** The seeder head is the most important part in the seeding unit. The seeder constructed from galvanized steel sheet of 1.25 mm thickness and the dimensions of 730 × 440 × 90 mm for length, width and depth respectively. The seeder position can be adjusted to forward or backward by two stands with slots and bolts. The seeder consists of two parts whose functions were coordinated to achieve the desired output. These were a seed plate and a vacuum system.

**Seed plate:** Two types of seed plate are designed with the same dimensions and the same holes position of two trays types which are used (84 and 209 cells). Each seed plate has other internal plate with the same holes diameter. The seed plate and internal plate are installed above each other by grooves and bolts. To adjust the seed plate holes size diameter either expand or reduce,

the internal plate can be moved left or right. The seed plate built-in with seed reservoir, that enough to fill multiple trays, one after the other, which allows for remarkably quick seeding. To move the seeds easily from the seed reservoir to the surface of seed plate and conversely, the groove along the seed reservoir axis was established.

**Vacuum system:** It consists of a vacuum flow chamber, a suction pump (1.2 kW and 2500 rpm), airflow-regulating valve, micro switch and air hose. Airflow-regulating valve is adjusted to obtain a specified optimum suction pressure for the used seeds and the negative pressure is measured with a vacuum gauge with an accuracy of 1.0 mbar.

As shown in Fig. 3 during the power switch of suction pump is switched on, the seeder is manually rotated on its axis from position (A) to position (B) which leading to the seed is sliding from reservoir (1) to seed plate surface, then the seed pickup operation is started. After that the seeder inversely rotated from position (B) to position (C) where, the seeds that have not been picking up are directly returning to reservoir seeds without falling down. In position (D) power switch of suction pump is automatically switched off by electric micro switch arm that touch the seeder to place one seed into the center of tray cells in certain position. Seeds would be completely released into all cells of tray per one operation cycle of seeder.

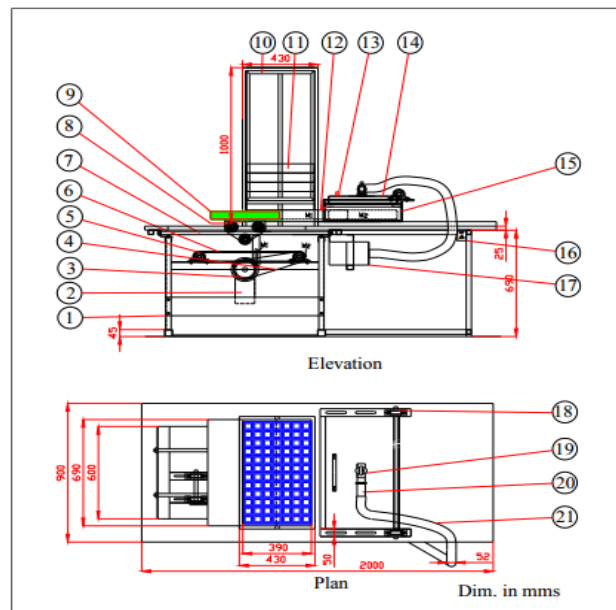

- |                    |                             |                                   |
|--------------------|-----------------------------|-----------------------------------|
| 1. Mainframe.      | 8. Reciprocating mechanism. | 15. Seeder stand.                 |
| 2. Electric motor. | 9. Sliding wooden drawer.   | 16. Power switch.                 |
| 3. Gear box.       | 10. Trays hopper.           | 17. Suction pump.                 |
| 4. V-belt.         | 11. Trays.                  | 18. Rotating shaft.               |
| 5. Ball bearing.   | 12. Micro switch.           | 19. Airflow-regulating valve.     |
| 6. Chain.          | 13. Seeder handle.          | 20. A joint link of suction hose. |
| 7. Table.          | 14. Head seeder.            | 21. Suction hose.                 |

**Fig. 1: Schematic diagram of the trays seeder**



**Fig. 2: Photo of the trays seeder**

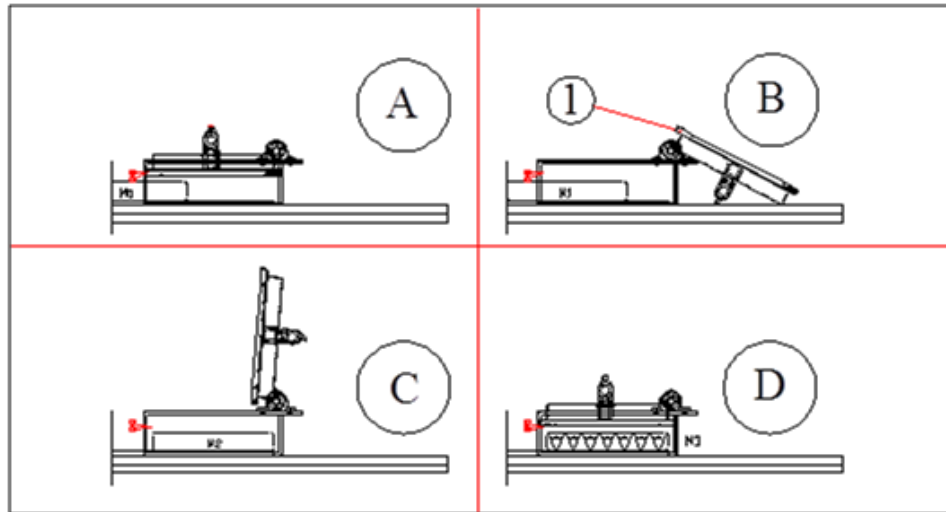

1-Reservoir.

Fig. 3: Operational sequence of the trays seeder.

**Transmission system:** The sliding drawer is mounted on a horizontal Scotch yoke mechanism to convert the rotational motion into the linear motion, reciprocating motion, Fig. 4). The sliding carrier (reciprocating part) is directly coupled to a sliding yoke (No. 2) with a slot that engages a pin (No. 6) on the rotating chain. The chain length was adjusted to obtain a horizontal stroke length of 500 mm to be greater than the wide tray.

Scotch yoke mechanism is driven by 0.3kW, single phase electric motor. The motor is directly connected with gear box to reduce the speed from 1450 to 29 rpm (50:1), and convert the vertical rotational motion to horizontal. The power of motor was transmitted to chain between two sprockets using pulleys, ball bearings (20 mm ID) and V-shaped belts. The seeder has been regulated to operate at constant speed (0.07 m/s).

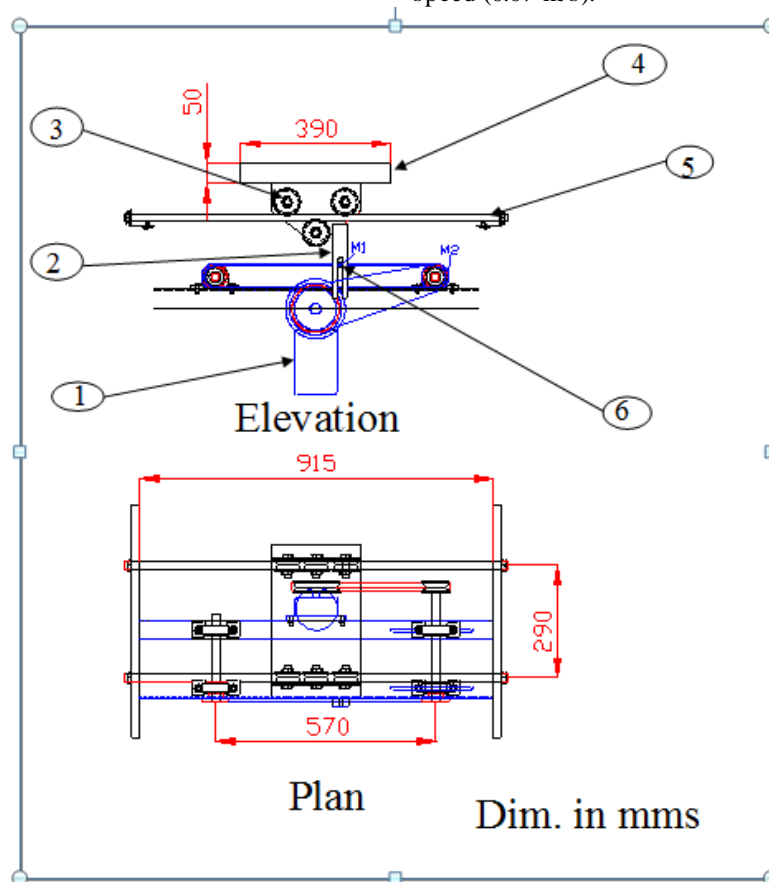

- |                    |                            |        |
|--------------------|----------------------------|--------|
| 1. Electric motor. | 3. V-shaped sliding pulley | 5. bar |
| 2. Sliding yoke    | 4. Sliding wooden drawer.  | 6. Pin |

Fig. 4: Schematic diagram of transmission system components.

### Experimental Procedures:

The experiments were conducted at the laboratory of Agricultural Engineering Research Institute (AEnRI), Dokki-Giza in 2015. Cucumber and cabbage seeds are selected to determine the seeds physical properties and evaluate the prototype performance. The measured and calculated physical properties of two seeds types are shown in Table 1. The properties are determined using the following methods:

- Linear dimensions, which include (*L*: length, *W*: width and *T*: thickness), a sample of 100 seeds were determined using a vernier digital caliper with an accuracy of 0.01 mm.
- Geometric mean diameter ( $D_g$ ) of the seeds is very essential for designing the hole diameter on the seed

plate and is calculated using Equation: 1 (Singh *et al.*, 2005):

$$D_g = (LWT)^{1/3} \quad (1)$$

- Sphericity ( $\phi$ ) of the seeds is calculated using Equation: 2 (Abalone *et al.*, 2004):

$$\phi = \frac{D_g}{L} = \frac{(LWT)^{1/3}}{L} \quad (2)$$

- One thousand seed mass was measured using an electronic balance with an accuracy of 0.01 g.
- Repose angle of seeds is determined using a digital instrument construct in the workshop of Agric. Eng. Department, Agric. Res. Center (ARC).

**Table 1: Physical properties of cucumber and cabbage seeds**

Properties	Seeds types					
	Average	Cucumber SD	CV	Average	Cabbage SD	CV
Length, <i>L</i> , (mm)	9.84	±0.47	4.76	2.12	±0.11	5.10
Width, <i>W</i> , (mm)	4.02	±0.18	4.55	1.87	±0.10	5.23
Thickness, <i>T</i> , (mm)	1.32	±0.25	19.11	1.74	±0.09	5.28
Geometric mean diameter, $D_g$ , (mm)	3.67	±0.26	7.17	1.89	±0.08	4.37
Sphericity, $\phi$ , (decimal)	0.37	±0.03	8.41	0.89	±0.02	2.21
One thousand mass, $M_{1000}$ , (g)	28.02	±0.36	1.27	3.68	±0.14	3.68
Repose angle, (deg)	38.80	±0.84	2.16	26.00	±1.58	6.08

SD: Standard division

CV: Coefficient of variation

### Design Principle:

#### Determining the hole diameter of seed plate:

To prevent the seed from entering the seed opening (hole), angle of edges openings on the seed plate may be conical in shape to be completely closed by a seed to avoid multiple seeds being picked up by the seed plate (Singh *et al.*, 2005). According to Bakhtiar, (2012) and Singh *et al.*, (2005) showed the most suitable conical angle of the seed plate is 120°.

According to (Singh, *et al.*, 2005) considered the opening diameter ( $d_o$ ) based on the less than or equal 50% size of the geometric mean diameter ( $d_o \leq 50\% Dg$ ). Due to this study, the geometric mean diameters of seeds are  $Dg = 3.67$  mm for cucumber and 1.89 mm cabbage (Table 1), Thus:

$d_o \leq 0.50 \times 3.67$  mm. Then  $d_o \leq 1.84$  mm for cucumber.

$d_o \leq 0.50 \times 1.89$  mm. Then  $d_o \leq 0.95$  mm for cabbage.

#### Prototype Performance Evaluation:

The performance evaluation of the vacuum trays seeder prototype is tested by seeding single seed of cucumber and cabbage seeds in the trays with 84 cells and trays with 209 cells respectively. The experiments were conducted with four different hole size diameters of seed plate (1.2, 1.4, 1.6, 1.8 mm) & (0.4, 0.6, 0.8, 1.0 mm) and four suction pressure levels of suction pump (5 (0.5), 10 (1), 15 (1.5) and 20 mbar (2 kPa)) & (3 (0.3), 6 (0.6), 9 (0.9) and 12 mbar (1.2 kPa)) for cucumber and cabbage seeds respectively. Three replicates for each experiment were conducted to measure the performance of the seeder using the singulation efficiency, seed utilization efficiency, seeding efficiency and the seeder productivity were expressed by (Gaikwad and Sirohi

2008) for both cucumber and cabbage seeds. The specific energy requirement and the seeding operation costs are also considering.

**Singulation efficiency:** is the ratio in percentage for singles percentage to the percentage of total cells seeded, where the numbers of seeds which placed in each cell were counted and attributed to total cells of trays to calculate % singles, % doubles, % multiples, % miss and % total cells seeded.

**Seed utilization efficiency:** is defined as the percentage ratio of total cells seeded to the total seeds in all cells.

**Seeding efficiency:** is also the total % of singles, doubles and multiples picked.

**The seeder productivity:** is determined in terms of the number of trays sown per hour.

#### Specific energy consumption (SEC):

SEC, kWh tray<sup>-1</sup> is calculated using the following equation:

$$SEC (kWh Mg^{-1}) = \frac{P (Power, kW)}{Pr (Productivity, tray h^{-1})} \quad (3)$$

**Power requirement:** The total power requirement (P, kW) for seeder prototype included both the power of seeder with electric motor and the power of suction pump. The total machine power was estimated from the following equation (Chancellor, 1981):

$$P = (I \times V \times \cos \theta) / 1000 \quad (4)$$

#### Where:

P: Total power requirement for the seeder, kW.

I: Current strength, Amperes.

V: Potential difference, Voltage.

Cos  $\theta$ : Power factor, equal 0.85.

### Cost analysis:

The cost per hour of operation for the precision vacuum seeder was estimated as following:

#### Fixed and variable costs of the seeder:

Fixed, variable and total costs can be calculated using the following equations (Suliman, 2007):

#### Fixed costs ( $F_c$ ):

$$\text{Fixed cost (EGP/h)} = D + I + Si (0.045 P_m) / \text{hour of use per year} \quad (5)$$

#### Where:

D: Depreciation costs, EGP/ year [=  $P_m - S_a / L_m$ ],  $P_m$ : Machine purchase price, = 4000 EGP,  $S_a$ : Salvage rate = 0.1  $P_m$ ,  $L_m$ : Machine life = 7 years,

I: Interest costs, EGP/ year [=  $(P_m + S_a / 2) \times i_n$ ],  $i_n$ : Interest rate = 10 %,

$$\text{Total costs (EGP/h)} = \text{Fixed costs (EGP/h)} + \text{Variable costs, (EGP/h)} \quad (7)$$

$$\text{Total costs include profit (EGP/h)} = \text{Total costs (EGP/h)} \times \text{Profit (1.20 \%)} \quad (8)$$

$$\text{Total cost (EGP/tray)} = \text{Total costs include profit (EGP/h)} \div \text{Productivity (Tray/h)} \quad (9)$$

$$\text{Seeding trays manually (EGP/tray)} = \text{Salary of one labor (7 EGP/h)} \div \text{No. of seeding trays/h (6 and 15 trays for 209 and 84 cells/tray respectively)}. \quad (10)$$

Si: Shelter, taxes and insurance costs, EGP/ year = 0.045  $P_m$  and Yearly operation = 500 hour/ year.

#### Variable (operating) costs ( $V_c$ ):

$$\text{Variable costs (EGP/h)} = R_m + E + L_a \quad (6)$$

#### Where:

$R_m$ : Repair and maintenance costs, EGP/ h (=100 % of D),

E: Energy (electricity) costs, EGP/ h [=Total electric power requirement, (1.0 kW)  $\times$  Electricity price, (0.45 EGP / kWh)] and

$L_a$ : Labor costs, EGP/ h [= Salary of one labor, (7 EGP / h)  $\times$  No. of labors (2)].

#### Total costs ( $T_c$ ):

## RESULTS AND DISCUSSION

### Seed Catching Performance Evaluation for Precision Trays Seeder:

#### 1-The optimum suction pressure:

Figs. 5 and 6 show percentages of singles, doubles, multiples and miss for cucumber and cabbage seeds catching performance as affected by different suction pressures of suction pump and different hole size diameters of seed plate.

Fig. 5 indicated that % singles for cucumber seeds increased by increasing the suction pressures from 5 to 15 mbar (from 51.2 to 75.0 %), while % miss decreased by increasing the suction pressure from 5 to 20 mbar (from 48.8 to 8.3 %) at 1.2 mm hole seed plate diameter. By increase the suction pressures from 5 to 10 mbar the % singles increased from 69.0 to 86.9, from 79.8 to 90.5 and from 84.5 to 89.3 % at 1.4, 1.6 and 1.8 mm of hole size diameters respectively. It can be seen that by increasing the suction pressures from 5 to 20 mbar the % multiples increased more than the % doubles, while the % miss of cucumber seeds decreased by increasing the suction pressures under all different hole diameters. Generally, the proper suction pressure was 15 mbar that recorded the highest % of cucumber singles seeds (90.5%) under 1.6 mm hole diameter. At these operating parameters no % of multiples seeds, the % doubles and miss seeds were 2.4 and 7.1 % respectively.

Referring to Fig. 6 by increasing the suction pressure from 3 to 9 mbar the % singles for cabbage seeds rapidly increased from 47.8 to 63.2, from 45.9 to 65.1, from 41.1 to 70.8 and from 39.2 to 58.9 % under all hole size diameters from 0.4 to 1.0 mm respectively. While the corresponding decrease for the % miss was obtained under the previous conditions. This means that, the greater the suction pressure from 3 to 9 mbar under all hole diameters, the greater the percentage of singles seeds conversely, the lower percentage of miss seeds. On the other hand the highest value percentages of doubles (26.8 %) and multiples seeds (39.2 %) were

recorded at 12 mbar under 0.4 and 1.0 mm hole diameters respectively.

The highest percentage of singles seeds was 70.8 % that considered the proper suction pressure (9 mbar) under hole diameter (0.8 mm). At these conditions the percentage of doubles, multiples and miss cabbage seeds were 9.1, 1.9 and 18.2 % respectively.

#### 2-The optimum hole size diameter:

Fig. 5 revealed that % singles for cucumber seeds increased by increasing the hole diameter from 1.2 to 1.8 mm under 5 and 10 mbar while, % singles rapidly decreased from 1.2 to 1.8 of hole diameters under 15 and 20 mbar respectively. This is may be due to the effect of suction pressure was observed more than the effect of hole diameters which resulted in a corresponding increase in the % seeds doubles and multiples. Obtained results are in accordance with Gaikwad and Sirohi, (2008).

On the other hand, at highest values (20 mbar) of suction pressure and highest values (1.8 mm) of hole diameter did not show any % of seed miss while, at these conditions the % doubles and multiples were increased by increasing the different hole diameters, which causes to reduce in the % singles to 16.7%.

It be concluded that the dual interaction effect between the suction pressure and hole diameter gave the proper result of % singles at 1.6 mm (90.5%) followed by at 1.8 mm (89.3%) of hole diameters under 10 mbar of suction pressure.

The optimum hole diameters for seed cabbage identified as shown in Fig. 6. Generally, increasing the hole diameter from 0.4 to 1.0 mm the % of singles cabbage seeds decreased under different of suction pressure except at 9 mbar suction pressure. For example, by increase the hole diameter from 0.4 to 1.0 mm the % of singles seeds decreased from 47.8 to 39.2 % at 3 bar of suction pressure. While during increase the hole diameter from 0.4 to 0.8 mm the % of singles slowly increase from 63.2 to 70.8 at 9 mbar of suction pressure respectively. Generally the proper % singles was recorded (70.8 %) at 9 mbar of suction pressure under 0.8 mm hole diameter.

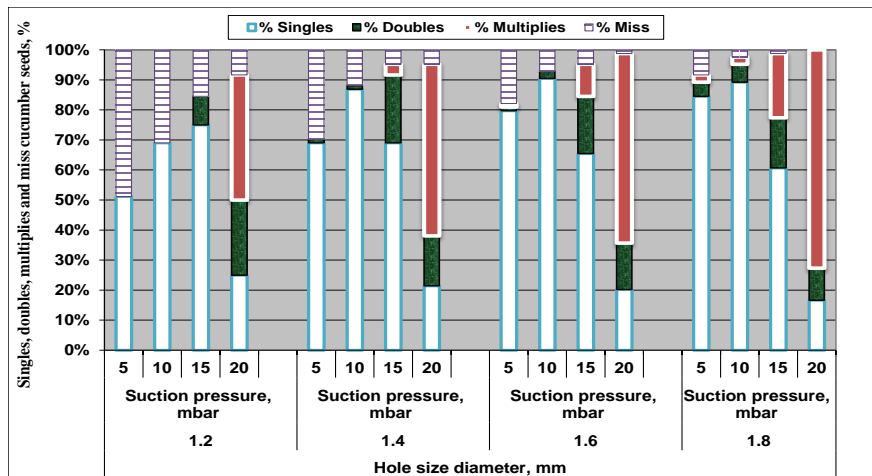

Fig. 5: Effect of suction pressure and hole size diameter on cucumber seeds catching performance.

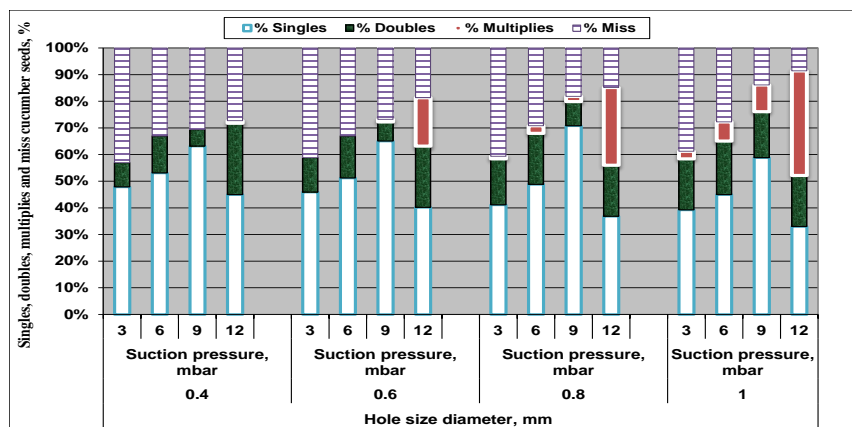

Fig. 6: Effect of suction pressure and hole size diameter on cabbage seeds catching performance.

### 3- Efficiencies for the precision trays seeder:

Table 2 show the Singulation, seed utilization and seeding efficiency at the proper suction pressure and hole size diameter for both cucumber and cabbage seeds. It could be noticed that the efficiencies for cucumber seeds recorded the higher efficiencies of seed catching than that the cabbage seeds by 10 %. These results revealed that the larger the seeds size the higher the seeds catching efficiency. So the use coated mechanism of fine seeds is necessary to obtain a higher percentage of seeding singles.

Table 2: Seeder efficiencies for cucumber and cabbage seeds.

Seeds	% Singles	% Doubles	% Multiples	% Miss	% Cells seeded
Cucumber	90.5	2.4	0.0	7.1	92.9
Cabbage	70.8	9.1	1.9	18.2	81.8
Seed	Singulation efficiency		Seed utilization efficiency		Seeding efficiency
Cucumber	0.97		0.98		0.93
Cabbage	0.87		0.84		0.82

### 4- Productivity and specific energy consumption:

The productivity of precision vacuum trays seeder was 240 tray h<sup>-1</sup> (20160 and 50160 cells h<sup>-1</sup>) for cucumber and cabbage seeds respectively, this in comparison with 1225 cells h<sup>-1</sup> (6 and 15 trays h<sup>-1</sup> for

209 and 84 cells tray<sup>-1</sup>) for seeding trays manually (Gaikwad and Sirohi, 2008). This mean that the productivity of trays seeder reduced the seeding time about 16 and 40 times than that the seeding trays manually for cucumber and cabbage respectively.

The consumed specific energy ( $4.16 \times 10^{-3}$  kWh tray<sup>-1</sup>) was obtained at the proper variables for both cucumber and cabbage seeds using the developed seeder.

### Cost analysis

The total hourly cost for precision vacuum trays seeder was 20.77 EGP h<sup>-1</sup> and the estimated cost was 0.1 EGP tray<sup>-1</sup>, this is in comparison with 0.5 and 1.2 EGP tray<sup>-1</sup> for hand seeding trays for cucumber and cabbage respectively. This means that the precision vacuum trays seeder reduced the estimated cost by 5 to 12 times than the hand seeding trays for cucumber and cabbage respectively.

## CONCLUSION

A precision vacuum trays seeder was developed and tested for seeding single seed in the trays (84 and 209 cells) for cucumber and cabbage seeds under four different suction pressure and four different hole size

diameters of seed plate. From the obtained results it can be summarized that,

- ♦ The proper suction pressure was obtained at 15 and 9 mbar and the proper hole size diameter was obtained at 1.6 and 0.8 mm for catching single seed of cucumber and cabbage which gave 90.5 and 70.4 % respectively.
- ♦ The efficiencies for cucumber seeds was higher efficiencies of seed catching than that the cabbage seeds by 10 %.
- ♦ The productivity of trays seeder reduced the seeding time about 16 and 40 times than that the seeding trays manually for cucumber and cabbage respectively.
- ♦ The total hourly cost for precision trays seeder was 20.77 EGP h<sup>-1</sup> and the estimated cost was 0.1 EGP tray<sup>-1</sup>, this is in comparison with 0.5 and 1.2 EGP tray<sup>-1</sup> for hand seeding trays of cucumber and cabbage respectively.
- ♦ It can be recommended that the use coated mechanism of fine seeds (cabbage seeds) is necessary to obtain a higher percentage of seeding singles.

## REFERENCES

- Abalone, R., A., Cassinera, A., Gastón & M. A., Lara (2004). Some physical properties of amaranth seeds. *Biosystems Engineering*, 89(1): 109-117. doi: 10.1016 / J. Biosystemseng. 2004.06.012.
- Bakhtiari, M. R. (2012). Design, development and evaluation of a kenaf pneumatic seeding machine. PhD Thesis, Universiri Putra Malaysia, Kuala Lumpur, Malaysia. Retrieved from <http://www.upm.edu.my>.
- Chancellor, W. J. (1981). Substituting information for energy in agricultural. *ASAE*, Paper No. 0001-2351.
- Gaikwad, B. B. and N. P. S. Sirohi (2008). Design of a low-cost pneumatic seeder for nursery trays. *Biosystems Engineering*, 99: 322– 329.
- Hassan, H. A. (2014). Developing an automatic mechanism for precision seeder. M.Sc. Thesis. Agric. Eng. Dept., Agric. Fac. Mansoura Univ.
- Hu, J.; J. Hou and H. Mao (2003). Development and test of magnetic precision seeder for seedlings. *Transactions of Chinese Society of Agricultural Engineering*, 19(6): 122–125.
- Ismail, Z. E. (2004). The first report of project (Developing the metering unit of the pneumatic planter) financed by Mansoura university researches unite.
- Ismail, Z. E.; M. M. Abo-Habaga; A. E. Abou Elmagd and H. A. Hassan (2014). Investigate a prototype for tomatoes precision seeder. *Misr J. Ag. Eng.*, 31(4): 1259- 1276.
- Kim, D. E.; Y. S. Chang; S. H. Kim and G. I. Lee (2003). Development of vacuum nozzle seeder for cucurbitaceous seeds (I) - design factors for vacuum seeding large sized seeds. *Journal of the Korean Society for Agricultural Machinery*, 28(6): 525–530.
- Singh, R. C., G., Singh & D. C. Saraswat (2005). Optimisation of design and operational parameters of a pneumatic seed metering device for planting cottonseeds. *Biosystems Engineering*, 92(4): 429-438.
- Sriwongras P. and P. Dostal (2013). Development of seeder for tray. *Mendel net: 867-871*. [https://mnet.mendelu.cz/mendelnet2013/articles/4\\_7\\_sriwongras\\_794.pdf](https://mnet.mendelu.cz/mendelnet2013/articles/4_7_sriwongras_794.pdf).
- Suliman, A. (2007). Agricultural engineering management systems - Agriculture economics and food. *Dare Ifikrelarabi, Egypt*: 93-110. (In Arabic).
- Vavrina, C. S. and W. Summerhill (1992). Florida vegetable transplant producers survey, 1989–1990. *Hort Technology*, 2(4): 480–483.
- Zhang, D. and Y. Guo (2012). *Computer and Computing Technologies in Agriculture II*, (1).
- Zigmanov, P. (1997). Efficiency of Machine Sowing of Vegetable Seed into Containers p: 92. Novi Sad, Yugoslavia.

## تطوير آلة بذر خضر محلية الصنع تعمل بشفط الهواء لصوانى المشتل. حسام محمد طلبة الغباشي\* ، عادل محمد الاشقر\* ، طارق حسين محمد\* ويسرى عبد القوى شعبان\* مركز البحوث الزراعية – وزارة الزراعة - الدقي - الجيزة.

يهدف هذا البحث الى تطوير وتصنيع وتقييم اداء آلة بذر خضر محلية الصنع تعمل بنظام شفط الهواء لبذر بذرة واحدة داخل خلايا صوانى المشتل هذه الآلة تعمل بنظام التغذية الميكانيكية المستمرة لصوانى المشتل. تم استخدام نوعين من صوانى الفوم ذات ٨٤ و ٢٠٩ خلية بنفس الأبعاد (٦٧٣ × ٣٩٣ × ٦٠ مم للطول والعرض والعمق على التوالي) وذلك لبذر بذرة واحدة من بذور كل من الخيار والكرنب فى خلايا صوانى المشتل على التوالي. تم اختبار هذه الآلة بمعهد بحوث الهندسة الزراعية - دقي - جيزة عام ٢٠١٤م. تم تقييم اداء هذه الآلة تحت متغيرات دراسية مختلفة على النحو التالي: ١- ضغط شفط الهواء لآلة البذر وهي (٠.٥، ١.٠، ١.٥ و ٢.٠ كيلو باسكال لبذور الخيار) & (٠.٣، ٠.٦، ٠.٩ و ١.٢ كيلو باسكال لبذور الكرنب). ٢- قطر ثقب لوحة لقط البذور للآلة هي (١.٢، ١.٤، ١.٦ و ١.٨ مم لبذور الخيار) & (٠.٤، ٠.٦، ٠.٨ و ١.٠ مم لبذور الكرنب). تم تقييم عوامل الدراسة المختلفة باستخدام القياسات التالية: ١- الكفاءة الفردية للقط البذور. ٢- كفاءة استخدام البذور. ٣- كفاءة البذر. ٤- انتاجية آلة البذر. ٥- الطاقة النوعية المستهلكة. ٦- التكاليف الاقتصادية لتشغيل الآلة. وكانت أهم النتائج المتحصل عليها أنه يمكن استخدام الآلة تحت الدراسة عند ضغط شفط مقداره ١.٥ و ٠.٩ كيلو باسكال وكذلك قطر الثقوب لآلة البذر بمقدار ١.٦ و ٠.٨ مم لتعطى افضل نسبة لالتقاط البذور الفردية وهي ٩٠.٥ و ٧٠.٤ % لكل من بذور الخيار والكرنب على التوالي. انتاجية آلة البذر سجلت ٢٤٠ صينية/ساعة عندما كانت الطاقة النوعية المستهلكة ٤.١٦ × ١٠<sup>-٣</sup> كيلو وات ساعة/صينية وتعتبر آلة البذر المطورة اقتصادياً حيث انها تخفض التكاليف الاقتصادية من ٥ الى ١٢ مرة عن تكاليف البذر اليدوية داخل الصوانى وذلك لبذور الخيار والكرنب على التوالي.



