

RESPONSE SURFACE METHODS TO MAXIMIZE THE PICKUP MACHINE PERFORMANCE

Ismail, Z. E.

Agric. Eng. Dept., Mansoura University

ABSTRACT

Response surface methods (RSM) provide statistical tools for design and analysis of experiments aimed to optimize the process performance of pickup machine. At the final stages of process development, RSM illuminates the sweet spot where the high pick-up machine of in-specification parameters can be achieved at the lowest possible operation. The main objective of the present study has been concerned with a particular problem, associated with the pickup drum of the balers. That aim was seem to be achieved through developing a new design for the pickup drum, which its idea depend on using the picker chains and claw elevator chains instead of using the usual tines in the currently balers in the minister of the agriculture. This investigation carried out to study the effect of the engineering parameters of the four rotation speeds for the double job units (pickup plus elevating straw) for the proposed design, three of chassis tilt angles, three of straw feed rates and three levels of straw holder heights on the straw elevated efficiency and loss percentage for the proposed design. Also evaluate the machine performance by determining the machine field capacity and productivity. The results indicated that the best value of straw elevated quantity was 7.075 kg/min, which obtained at 102 rpm rotation speed of the combined units and straw feed rate 4 kg/min. For increasing the straw holder's heights from 0 to 2 cm increases the field capacity from 0.058 fed/h to 0.086 fed/h at decreasing the chassis tilt angles from 36 to 28 degree. Also increasing the straw holder's heights from 2 to 4 cm increases the field capacity from 0.06 to 0.096 fed/h at increasing tilt angles from 28 and 36 degree.

INTRODUCTION

Rice's straw is a major field-based residue that is produced in large amounts in Egypt. In fact, the total annual quantity equals about 3.1 million Ton (The statistics of the statistical and information center, 2007). From the varsity economics of utilizing rice straw are for energy, animal, chemical and construction material production. However, an increasing proportion of this rice straw undergoes field burning. Off-field utilization of rice straw has initiated improvements in straw handling techniques. One possible improvement involves using the mechanical balers to bale the straw. We have taken care in the present study to limit the technical problems that face the pickup unit in these machines and try to solve these problems.

The general review indicated that there are three types of conveyers. In one type, an auger conveys the hay or rice straw to asset of packer fingers, which sweep the straw into the bale chamber. In a second type, linear moving picker fingers travel across the full width of the pickup in conveying the straw into the bale chamber. In a third type, rotating finger wheels move the hay laterally to the packer fingers. Ismail *et al.* (2007) indicated that the type of pickup reel that is used on a mower-conditioner is also used on other machines, for example, forage harvesters and combines illustrate three

different types of mechanisms used in pickup reels. There are reeling teeth parallel with eccentric spider control, cam control and planetary gear control. Kamei and Yamana (1998) studied the effects of straw pickup operating speed on power requirements under a chain conveyor and a roller type. They showed that roller type offered higher packing density than the chain conveyor, but required more power, and the bale dry matter density per unit power was lower. While, Morad *et al.* (2002) found that the economic forward speed was 3.0 km/h corresponding to feed rates of 3.0, 2.4 and 5.7 ton/h for rice straw, wheat straw and alfalfa respectively. They mentioned that pickup baler forward speed between 2-3 km/h is recommended to optimize feed rate and minimize both baler losses and cost. They also mentioned that the plunger speed of 97 m/min is recommended to minimize the number of bales.

El- Ghonimey and Rostom (2002) studied four different balers, Welger (Ap 530), Class (55), CiCoria (747) and Galligan (5190), to evaluate their performance for handling rice straw. These types are similar in driving power source (PTO), pickup theory, and pressing operation theory, while they have some substation all differences in internal transmission mechanism, rate of performance, bales quality, and total costs. They found that the pick up losses increased by increasing each of the forward speeds of 2.5, 3.5 and 4.5 km/h respectively. Furthermore, they found that the arrangement of balers according to lowest baling cost was CiCoria (747), Class (55), Welger (Ap 530), and Galligan (5190).

Technical problems were analyzed in the baler's pick up units, which divided into the following; design problems and operation problems such as; the pickup fingers easily broken or bended during operation in the field. The side cam control, fixed bases, bearings, rings, bolts and nuts in pickup unit are wearing. The second problem is due to operation such as; the capacity of pickup is reduced or breaks down during operation it may be due to the conformed a heap of rice straw and also loading the sacks over trailers after harvesting lead to press the soil beneath the wheels and the baler cannot pick up rice straw from this places.

Therefore, the aim of the present study is to develop and manufacture a new pickup prototype for the balers instead of the current units. The developing unit designed to achieve two major purposes; first increasing the pickup efficiency, second to reduce the machine pickup losses and to improve the machine field capacity.

MATERIALS AND METHODS

The prototype was designed and constricted in the workshop technology of Agricultural Engineering at Mansoura University. As shown in Fig (1) the prototype unit consists of the header element, elevator unit, transmission system, the element suspension, the complementary parts and straw pickup chain units. The pickup plate, straw chains and straw holders are the main fractions of the header system, while the elevator unit has straw elevator chains (claw chains). The transmission powers were don in too two ways, the first to convey the power from tractor "PTO" to the elevator and the second

control on the finger's revolution of rotations. Referring to Fig (2), the straw pickup chain unit consists of pickup chain, chain frame (chain guide), sprocket, and holder bevel-shaft rear tension and side holders. Three points hitching system was used as connected the prototype with tractor.

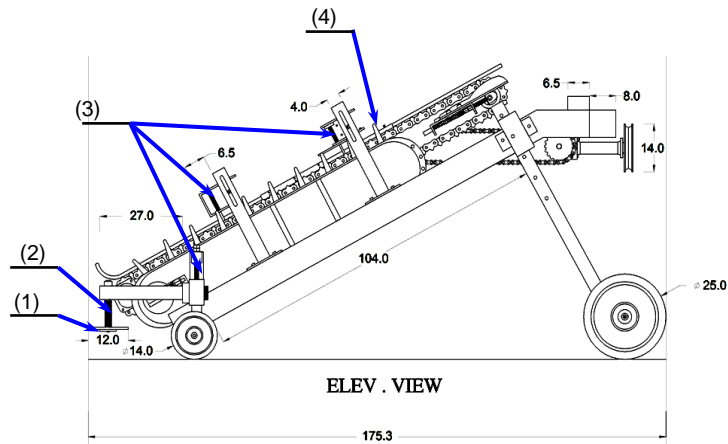

1- Rubber strips 2- Complementary parts 3- Springs 4- Finger holders
Fig. 1: The front pickup plate.

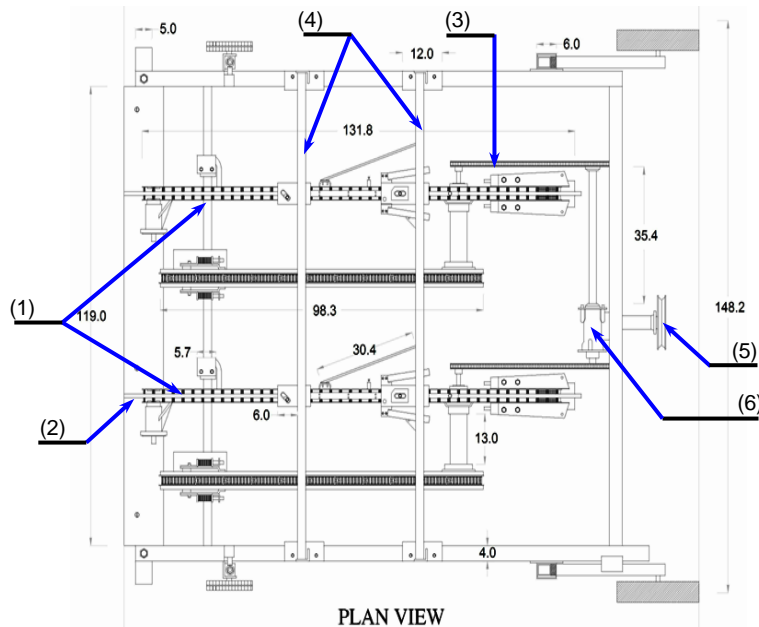

1- Pickup chain 2- Chain frame (chain guide) 3- Rear tension 4-Iron spiral shafts 5- Holder bevel shaft. 6- Input wheel driver
Fig. 2: The picker chain fixing.

Prototype operation

The straw elevator unit elevates the rice straw from the soil surface by picker to the storage unit. It is consisting of the pick-up and the straw elevator chains. The picker units are connected together with elevator units in double job units, which picking up plus elevating rice straw residues in one step. There are two units in the proposed design.

The elevator chains left the straw by it is fixed claws. There are eighteen claws fixed in one chain. The claws rotate in a path over the rails in the locked chains, case. The claw's path leads to appear nine claws only that left the straw and the other nine claws hidden in the case and ready to appear from the front of the chain's case. The claws made of a special kind of polyethylene that resists wearing. The distance between every two claws is (9 cm). The claw's chain has the rotation from the rear sprocket (20 teeth) that can be tightened by its frontage tension springs, which pull the front chain's roller. The face tension springs have two jobs; first make the chain tightened continually, second to absorb the shocks in case of the heavy load of rice straw to prevent the chain from cutting. The chain's case is (96 cm) length and fixed on the chassis by it is front stays.

Factors Tested

The experiments were carried out to study the effect of different operation conditions on the performance of the header and elevator unit of the prototype unit. The tests studied parameters are:

- 1- Four levels of the forward speed (F_v) that can be a change by changing the speed of the gear box of the Nasr tractor. The levels are 0.5, 0.70, 0.90 and 1.1 km/h that face 40, 58, 78, and 102 of the double job unit's rotation speed.
- 2- Three levels of chassis tilt angles that can be a change by the holes of the rear wheels slider's and the height of the front wheels by the tension's arms. These levels are 28°, 32° and 36°.
- 3- Three levels of straw feed rate (F_r), which can be a change by using different feed rates as the following: 2.0, 3.0 and 4.0 kg/minimum

The prototype evaluation

It was evaluated according to four main out-put parameters. These parameters are the prototype productivity (P , ton/h), the prototype capacity, the straw pickup efficiency and the pickup losses. All data collected at three different classes of rice with straw densities of, 2, 2.5 and 3.5 ton/fed.

1 -The productivity of the prototype (P , ton/h) was calculated as follows:

$$P = \frac{Pm}{Pt}$$

Where: Pm is straw picked mass, ton and
 Pt productivity time, h.

2- The prototype capacity (F_c , fed/h) for the three quantities of rice straw density (20, 3 and 4.0 ton straw per feddan) was calculated as follows:

$$F_c = P \times \frac{1}{z}$$

Where: Z = the feeding straw rate is equal 2.5 or 3.0 or 3.5 ton straw/fed respectively.

3- **The straw pickup efficiency (E, %):** it was calculated as follows:

$$E = \frac{Pm}{Sm} \%$$

4- **The straw pickup losses (L, %):** there were calculated as follows:

$$L = \frac{Sm - Pm}{Sm} \%$$

Where: *Pm*: straw picked mass, g and

Sm: mass of straw residues, g

The tests were replicated three times for each treatment of the prototype. The data were statistically analyzed using the Response Surface Methodology (Anderson and Whitcomb, 2007 and Myers and Montgomery, 2002) to determine the effect of the above variables on straw flow rate, machine efficiency and the unit capacity.

RUSULTS AND DISCUSSION

Response surface methods

The pickup machine performance desired a more robust result for machine productivity (the response output "Y") as a function of three key factors (the input "X"s) known to affect their machine performance such as the machine forward speed, pickup till angles, and straw feed rates. The central composite design (CCD) was used as a popular template for response surface methodology (RSM) because it requires only a fraction of all the possible combination from a full three-level factorial (Anderson and Whitcomb -2005 and Myers and Montgomery - 2002).

The table (1) shows the star project from the center point of the two-level factorial that located a prescribed distance along the three main factor's axes. For example, the medial point projecting out is identified by number 3 in table 1, is located 1.68 units from the center (coded 0) for forward speed variables as affected the prototype productivity, capacity and straw pickup efficiency.

To clarify the implications of this design geometry for the experiment, let's say that the current setting of a factor is 100 and the factorial range will be ± 10 . Then the upper point for the three-factor CCD would be set at 1.68 and the lower start an equal interval the center point at 100). These statistically-desirable distance as the number of factors goes up. However, the model-fit will be reliable only within the factorial box. Figures 3; 4 and 5 indicated the above relation for the un-depending variables (prototype productivity, capacity and straw pickup efficiency) as indicated by Robinson *et al.* (2005).

The CCD template calls for replication of the center point a number of times, ideally six for the best predictive properties in the middle region of experimentation (Derringer- 1994). However, these experimenters ran only four center points-still not bad. The actual run order, including center points, should always be done at random. Otherwise, the effects will become biased by prototype speed related lurking variables such as the prototype

productivity, machine capacity and efficiency, thus confounding true cause-and-effect relationships.

Table (1): Design matrix for RSM on straw pickup efficiency, productivity and field capacity.

Std	S	T	Fr	1	2	3
	forward speed	Till angle	Straw feed rate	Pick-up efficiency	Productivity	Field capacity
1	0.00000	0.00000	0.00000	97.21	0.047	0.543
2	0.00000	0.00000	0.00000	97.21	0.047	0.543
3	1.68179	0.00000	0.00000	94.38	0.054	0.368
4	0.00000	0.00000	0.00000	97.21	0.047	0.543
5	1.00000	1.00000	1.00000	76.34	0.042	0.429
6	-1.00000	1.00000	-1.00000	55.21	0.056	0.313
7	0.00000	0.00000	0.00000	97.21	0.047	0.543
8	0.00000	1.68179	0.00000	88.43	0.056	0.316
9	0.00000	0.00000	-1.68179	86.42	0.054	0.377
10	-1.00000	-1.00000	1.00000	74.21	0.034	0.261
11	0.00000	0.00000	0.00000	97.21	0.047	0.543
12	1.00000	-1.00000	1.00000	88.42	0.054	0.285
13	-1.00000	-1.00000	-1.00000	70.13	0.066	0.367
14	0.00000	0.00000	1.68179	84.32	0.047	0.238
15	-1.68179	0.00000	0.00000	83.42	0.064	0.421
16	0.00000	0.00000	0.00000	97.21	0.084	0.545
17	1.00000	-1.00000	-1.00000	60.41	0.063	0.423
18	-1.00000	1.00000	1.00000	66.69	0.086	0.543
19	1.00000	1.00000	-1.00000	56.42	0.121	0.472
20	0.00000	-1.68179	0.00000	66.74	0.066	0.423

Modeling the pickup and straw loss mean and variance

By collecting repeated samples for each run, experimenters can model both the mean (average) and variance (or standard deviation). This enables the following tactics for process optimization:-

- 1) From the mean response, find factor settings that meet the targeted response;
- 2) Use the statistics on variation to achieve operating conditions that are robust to uncontrolled (clatter) variables.

Ideally, the responses measured during the machine pickup efficiency of any given run under different variables. For example, the values for mean and standard deviation of the machine pickup efficiency are derived pre carried out the experiments in several run. That experimental run can suffice for this dual response approach. However, no matter what the sample size (n), if the study conditions are not representative of true experimental conditions, this method may underestimate the overall variation (ISMI, 2007).

Least-squares regression of the data produced for mean straw pickup efficiency and losses were:

$$E, \% = 92.77 + 7.57 t + 1.854 R - 1.92 H - 9.545 T^2 - 23.07 R^2 - 8.453 H^2 - 11.67 t.R + 21.36 t.H - 20.41 RH \quad (p < 0.0001, \text{Adjusted } R^2 = 0.84)$$

$$L, \% = -310.33 + 12.77 t + 7.97 R - 22.34 H - 0.21 T^2 - 0.04 R^2 - 4.71 H^2 - 0.07 t R + 2.37 t H - 0.63 R.H \quad (p < 0.0001, \text{Adjusted } R^2 = 0.76)$$

Both models are quadratic, i.e., second-order polynomials, and they are highly-significant statistically as indicated by their low "p" values and high adjusted R-squared values.

Referring to the response surface program, the plot data of variables till angle (T) and straw feed rate (Fr) is illustrating in Fig (6) at considering the effect of machine forward speed (S) as a straight line. This plot originates from the center point of the experimental region and from there it measures the response in each of the three-dimensional axes.

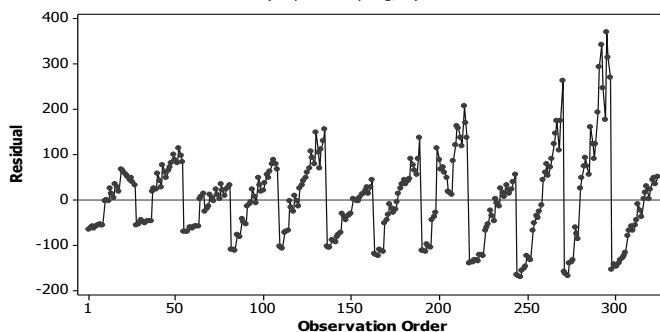

Fig. (3): The versus order of prototype productivity (kg/h)

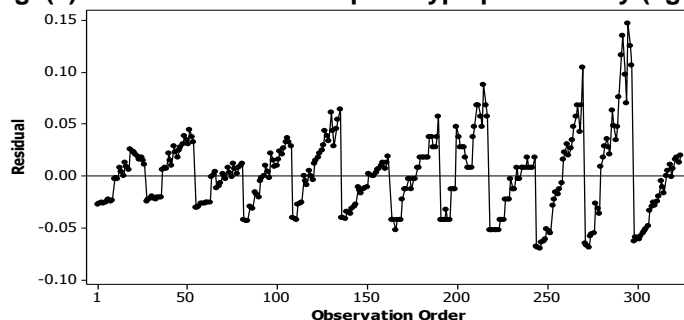

Fig. (4): The versus order of prototype capacity (fed/h)

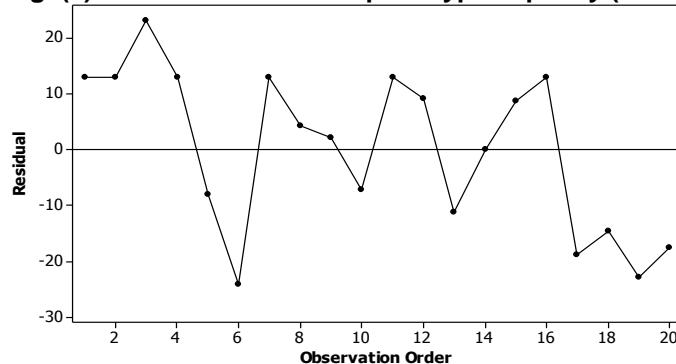
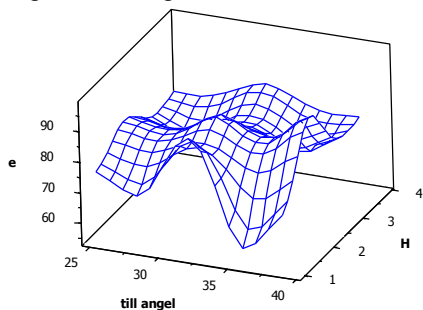

Fig. (5): The versus order of prototype capacity (fed/h)

The relationships between the machine forward speed (S), straw feed rate (Fr) and straw holder's heights (H) on the straw pick-up efficiency and losses at

the different chassis tilt angles (T) are illustrated in Fig (6). The results as shown in Fig (6-a) indicated that the highest value of straw pick-up efficiency was 97.4 % obtained at 40 rpm of the machine forward speed (S) and the chassis tilt angle was adjusted at 36 degree. While the highest value of straw pick-up losses was obtained at 102 rpm of the machine forward speeds (S) and the chassis tilt angle of 28 degree.



Surface plot of pick-up efficiency % via H and till angle.

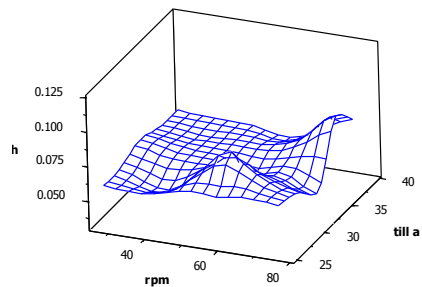

Surface plot of pick-up losses % via till angle and rpm.

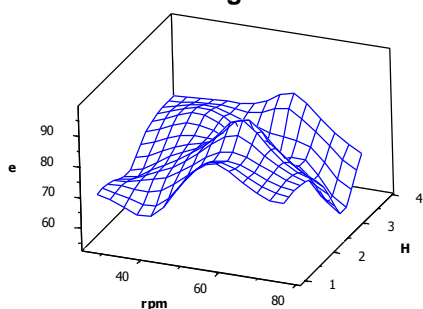

Surface plot of pick-up efficiency % via H and rpm.

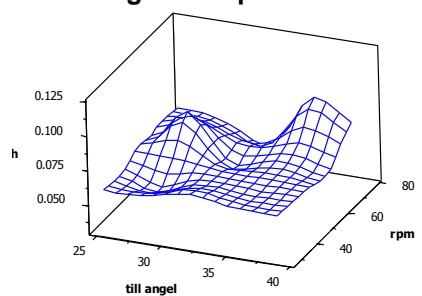

Surface plot of pick-up losses % via rpm and till angle.

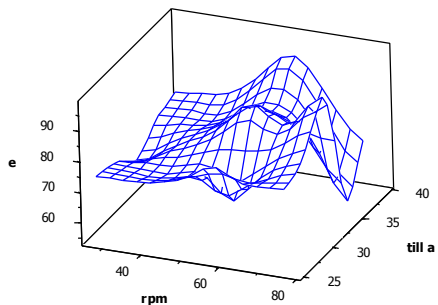

Surface plot of pick-up efficiency % via till angle and rpm.

Fig. (6-a): The machine straw pick-up efficiency via all variables.

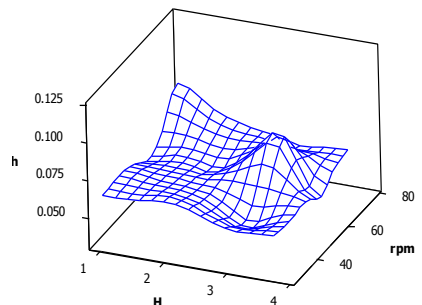

Surface plot of pick-up losses % via rpm and H.

Fig. (6-b): The machine straw pick-up losses via all variables.

The rates of the decrement are about “50.13 %” at increasing the machine forward speed (S) from 40 to 58 rpm, while this rate is decreased by “49.87 %”

at increasing the machine forward speed (S) from 78 to 102 rpm (Fig. 6-b). The vice versa was found at straw pick-up losses. The rate of straw losses increasing about “46.03 %” at increasing the combined unit speeds from 40 to 58 rpm. This rate is “53.97 %” at increasing the speed from 78 to 102 rpm (Fig. 6-b). On the other side, increasing the straw holder height the pick-up efficiency is decreased and the straw losses in percentage are increased.

The probability plot for machine pick up efficiency was illustrated in Fig. (7), the goodness of fit test at normal effect the line distribution (AD) was equal to 0.814 with the probability value of 0.029. But at Box-Cox transformation the AD equal 0.778 and P-Value was found of 0.036. Otherwise, for lognormal distribution the AD= 0.912 and P-Value = 0.016 and AD= 0.865 and height significant for P-Volume at 3-parameter lognormal analysis.

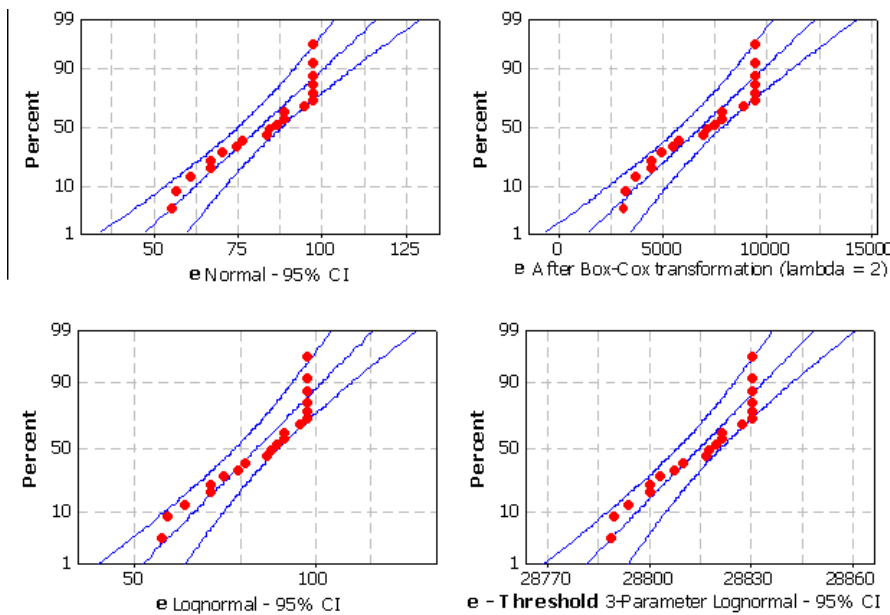

Fig. (7): The probability plot at machine pickup efficiency.

Modeling the prototype productivity mean and variance (Ton/h)

To verify the second aim of this paper, the machine productivity was conducted under different operation variables. Fig (8) illustrates the relationship between the rotation speeds on the straw machine productivity. The results indicated that the highest value of the designed unit productivity was 0.36 ton/h obtained at 102 rpm of the double job unit's rotation speeds and the chassis tilt angle was adjusted at 36 degree. Also the peak value of the designed unit productivity 0.326 ton/h was obtained at 4 cm of straw holders height and the straw feed rate was adjusted at 4 kg/min, while the lowest value of the designed unit productivity 0.107 ton/h was recorded at 0 cm height for the straw holders when the straw feed rate was adjusted at 2 kg/min. From Fig 8 increasing the double job unit rotation speed, rpm

decreasing the machine productivity from 2.5 to 2.44 ton/fed and then the relation increased at the tilt angle of 36 degree. The same trend was found at tilt angle of 32 degree.

A simple power regression analysis applied to relate the change in the designed unit productivity with the change in the double job unit's rotation speeds, chassis tilt angles, straw feed rates and straw holder height's for all treatment. The obtained regression equation was in the form of:

$$P = 0.05 - 0.006 t + 0.005 - 0.006 H + 0.013 t^2 + 0.013 R^2 + 0.003 H^2 + 0.004 t R - 0.23 t H + 0.004 RH \quad (R^2 = 0.97)$$

Where:

P: designed unit productivity, ton/h

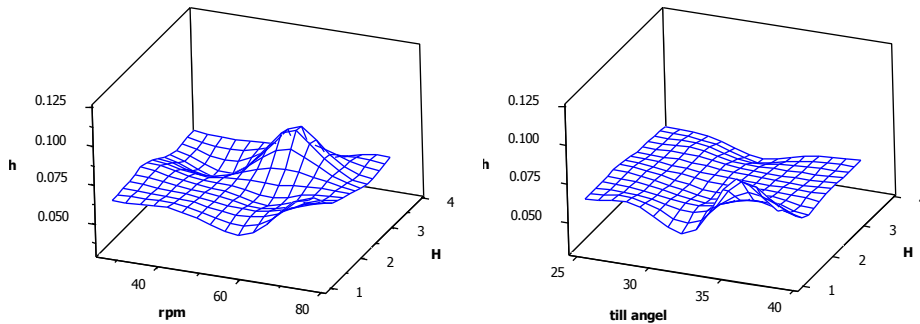

Surface plot of machine productivity via H and rpm	Surface plot of machine productivity via H and till angle
--	---

Fig (8): The machine productivity via all variables.

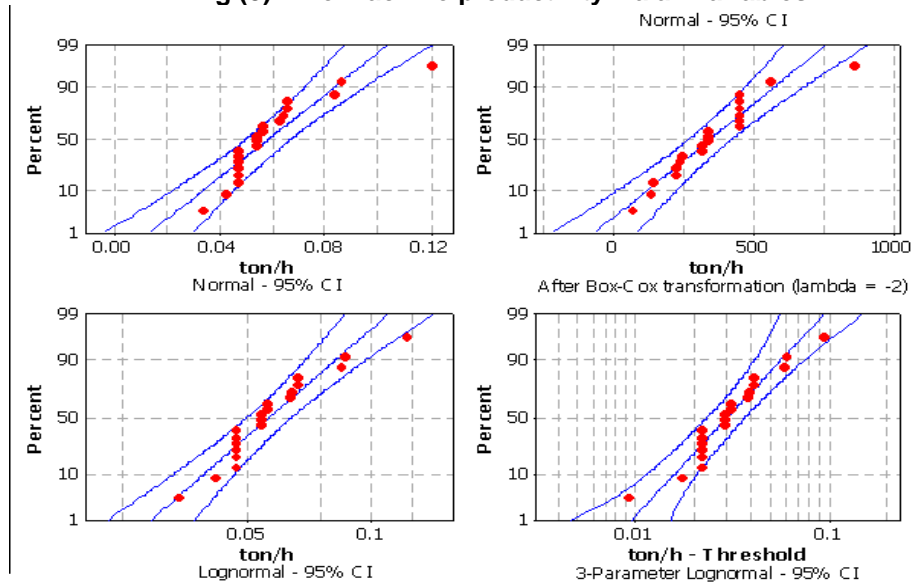
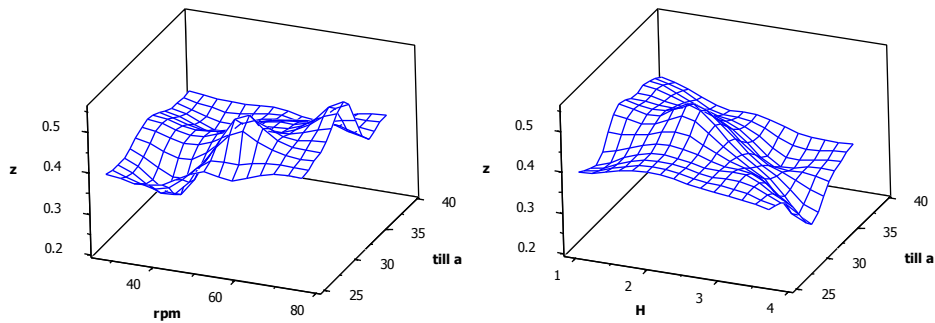

Fig (9): The probability plot at machine productivity.

The probability plot for the machine productivity was illustrated in Fig (9), the goodness of fit test at normal effect the line distribution (AD) was equal to 1.298 with the probability value of < 0.005 . But at Box-Cox transformation the AD equal 0.566 and P-Value was found of 0.124. Otherwise, for 3-Pognormal distribution the AD= 0.506 and P-Value was height significant and AD= 0.69 and P-Volume of 0.06 at lognormal analysis.

Modeling the prototype field capacity mean and variance (fed/h)

The regression of RSM that related the relation between in-put parameters (S, L and Fr) and prototype capacity coded predictive models. The total interaction between different treatments shows a significant effect with ($R^2 = 0.98$) and ($CV=8.8$). Fig 10 indicated the, there are a direct relationship between the double job unit's rotation speed and the designed unit capacity. By increasing the double job unit rotation speeds the designed unit capacity for the different straw densities increases at each of different chassis tilt angles, straw feed rates, and straw holder's height.



Surface plot of field capacity via till angle and rpm

Surface plot of field capacity via till angle and H

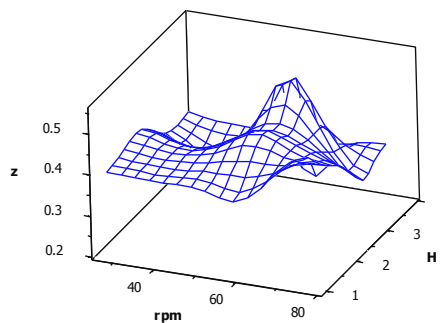

Surface plot of field capacity via H and rpm

Fig (10): The machine field capacity via all variables.

The probability plot for the machine field capacity was illustrated in Fig (11), the goodness of fit test at normal effect the line distribution (AD) was equal to 5.11 with the probability value of < 0.003 . But at 2-parameter exponential on the AD equal 1.57 and P-Value was found of 0.01. Otherwise,

for 3-Parameter Weibull the AD= 0.694 and P-Value was 0.076 and AD= 1.345 and P-Volume of <0.016 at Weibull analysis.

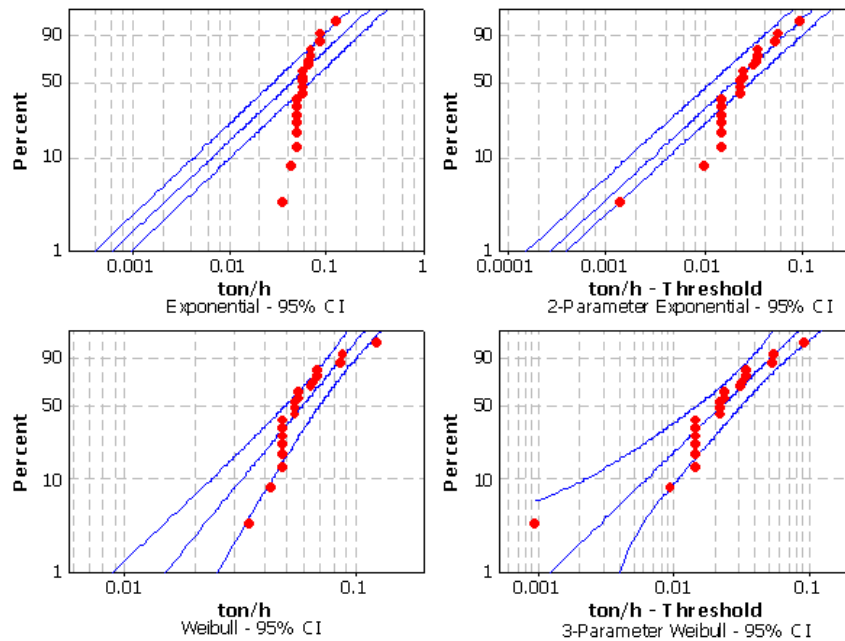

Fig (11): the probability plot at machine productivity.

REFERENCES

- Anderson M. J and P.J. Whitcomb (2005). *RSM Simplified — Optimizing Processes Using Response Surface Methods for Design of Experiments*, Productivity, Inc., New York.
- Anderson M. J and P.J. Whitcomb (2007). *DOE Simplified — Practical Tools for Effective Experimentation, 2nd Edition*, Productivity, Inc., New York.
- Derringer G. C (1994). "A Balancing Act: Optimizing a Product's Properties," *Quality Progress*, pp. 51-58 (posted with publishers permission at www.statease.com/pubs/derringer.pdf), June.
- El-Ghonimey, M.I. and Rostom, M.N. (2002). performance evaluation of different pick-up press balers towards for handling of rice straw *Misr J. Ag. Eng.*, 19 (3) :705-720.
- Ismail, Z.E.; E.B. El-Banna; M.M. Ibrahim; and M.A. Shalaby (2007). Developing the drum of Turkish threshing machine *Misr J. Ag. Eng.*, 32 (9): 7325-7332.
- ISMI (International SEMATECH Manufacturing Initiative) (2007). Symposium on Manufacturing Effectiveness, Private conversation Austin, TX, October.
- Kamei, M.; and N. Yamana (1998). Packing characteristics of small fixed chamber type roll baler. *Journal of the Japanese Society of Agricultural Machinery*. 60 (2): 111-116.

- Morad, M. M. , A. E. Hashish, A. F. Abd El-Mottaleb and A. M. El-Shal (2002). Effect of some operating parameters on pick-up baler performance. *Misr J. Ag. Eng.*, 19 (1): 136-158.
- Myers R. H and D. C. Montgomery (2002). *Response Surface Methodology*, problem 2.21, John Wiley and Sons, Inc., New York.
- Robinson T. J; S. S. Wulff and D. C. Montgomery (2006). "Robust Parameter Design Using Generalized Linear Mixed Models," *Jour. of Quality Tech.*, Vol. 38, No. 1, p. 70, Table 1.
- The statistics of the statistical and information center (2007). Agricultural machinery management data. Standards, 45th Ed. St. Joseph, MI: ASAE, D497.1.

طرق استجابة السطح لتعظيم أداء اله اللقط

زكريا ابراهيم اسماعيل

قسم الهندسة الزراعية – جامعة المنصورة

طرق استجابة السطح أداءه إحصائية تستخدم في تصميم وتحليل التجارب بهدف تعظيم أداء عمليات آلة اللقط في المراحل النهائية لعمليات التطوير طريقة استجابة السطح تسلط الضوء على أعلى مواصفات أداء آلي للقط يمكن الوصول إليها بأقل عمليات ممكنة. والهدف الأساسي من هذه الدراسة يهتم بحل المشكلات التي تواجه بصفة خاصة إسطوانة اللقط في آلات عمل البالات. هذا الهدف يمكن تحقيقه من خلال تطوير تصميم جديد لإسطوانة اللقط والتي تعتمد فكرة عملها على إستخدان سلسلة لقط ورافع سلسيلى ذو أصابع بدلاً من إستخدام الشوك المعتاد إستخدامها في آلات التبييل المستخدمة الآن في وزارة الزراعة. هذا البحث يبحث في دراسة تأثير العوامل الهندسية لأربع سرعات دورانية للوحدة المزودة الوظائف (وحدة لقط ورفع القش)، وثلاث زوايا لميل الإطار، وثلاث معدلات تغذية للقش، وإرتفاعات مستويات اللقط على كفاءة رفع القش، والنسبة المئوية للفقء. وأيضاً تقييم الأداء الآلى بتحديد سعة الآلة وإنتاجيتها.

وقد أوضحت النتائج أن أفضل كمية مرفوعة من القش كانت ٧.٠٧٥ كجم/دقيقة والتي تم الحصول عليها عند سرعات دورانية للوحدة المزودة الوظائف ١٠٢ لفة/دقيقة، ومعدل تغذية للقش ٤ كجم/دقيقة. وبزيادة إرتفاعات مستويات اللقط من صفر إلى ٢ سم زادت سعة الآلة من ٠.٥٨ إلى ٠.٨٦ فدان/ساعة وذلك عند إنخفاض زاوية ميل الإطار من ٣٦ إلى ٢٨ درجة. وأيضاً بزيادة إرتفاعات مستويات اللقط من ٢ إلى ٤ سم زادت سعة الآلة من ٠.٦٠ إلى ٠.٩٦ فدان/ساعة وذلك عند إنخفاض زاوية ميل الإطار من ٣٦ إلى ٢٨ درجة.

قام بتحكيم البحث

كلية الزراعة – جامعة المنصورة
كلية الزراعة – جامعة قناة السويس

أ.د / حسنى الشبراوى المرسى
أ.د / شريف عبد الحق رضوان