

Developing a Grading Machine for Eggplant

Amin, E. E.; T. H. El-Shabrawy and Shaimaa I. Abd El-kader

Agric. Eng., Dept. Fac. of Agric. Mansoura Univ., Egypt.



ABSTRACT

A small grading machine was developed, fabricated and evaluated technically and economically based on spherical crops such as Baladi eggplant variety. Grading acts by using cylinder system of rod for grading system be used in small horticultural holdings, small grading stations and small factories. The effect of some parameters such as drum speed of grading unit (0.31; 0.41; 0.59) m/sec and slope angle of grading unit (0.0; 1.0; 2.0; 3.0 deg.). The grading machine capacity (ton/h), grading efficiency (%), mechanical damage of eggplant (%) and specific energy consumption (kW. h/ton) and total operation cost (LE / ton), were studied to evaluate the grading prototype. The best results were obtained at drum speed 0.41 m/sec and grading slope angle 2.0 degree. At above variables the maximum grading efficiency recorded 84.6 %, damage index of 5.08 %, specific energy consumption of 0.32 kW. h/ton and total productivity cost for one ton was 5.62 LE / ton for Baladi eggplant variety.

INTRODUCTION

In Egypt, The cultivated area of vegetables crops is 759.683 thousand feddans that produces 8.33 million tons /year, (Ministry of Agricultural and Land Reclamation, 2015). Eggplant (*Solanum melongena* L.) is the fifth most economically important Solanaceous crop after potato, tomato, pepper, and tobacco, (Taher, *et al.*, 2017). Egypt produces about 1 million ton /year of eggplant, (FAO, 2018).

USA standards for eggplant grades, (2013) mentioned that the largest eggplant diameter considered the main parameter affecting on grading. Eggplant sizing can be determined in terms of count minimum diameter or diameter range in the container. Eggplant packed must be reasonably homogeneous, unless the diameter range is specified.

Ukey and Linde, (2010) developed a sapota fruit grader to increase the output of fruit grading and save time and labor. A sapota fruit grader based on divergent roller type principle was designed and developed. The best combination of roller speed, its inclination and roller gap was found to be 223 rpm, 4.5 and 38 to 64 mm, respectively for highest efficiency of 89.5%. The capacity of machine was 1440 kg/h.

Amin, (1994) developed and tested a classification system consisting of a rotor cylinder and a perforated handle for the classification of potatoes, onions and oranges, The results showed that, crop parameters such as tuber dimensions and mass and machine performance such as cell area, shape, drum speed, and cylinder axis slope angle and the length of the cylinder were a significant impact on the efficiency of the staging. He adding that, the prototype efficiency was at drum speed of 25 rpm; zero sloping degree; feeding rate 1.2 kg/h which caused tuber damage of 0.23%.

Prasad, (2015) mentioned that the post-harvest losses for eggplant Okra and tomatoes ranged from 25.2 to 40.4. 23.9 to 31.5 and 19.5 to 31 %, respectively. There was a total average post-harvest loss of 32.8% for eggplant and 27.5% for the okra and 25.8% for the tomatoes along the post-Harvest series. The post-harvest loss resulting from the experimental was relatively similar at 7.8% and 8.7% for the eggplant and okra, respectively.

The objective of the present study is to develop, fabricated and evaluate technically and economically a grading machine acts by drums for grading system. The developed grading machine is to be used in small horticultural holdings, small grading station and small food factories.

MATERIALS AND METHODS

The developed machine

The proposed grading machine used in this study was developed, installed and tested at the workshop of Mit Ali, Mansoura, Egypt. The experiments were carried out on Baladi eggplant variety. The specific of grading machine elements as presented in Figures (1 and 2) consists of five main parts as follows:

- 1. Main frame** was constructed form steel angle (4×4 cm), 0.5 cm thick welded together with dimension of 320 cm length, 68 cm width and 100 cm height. All parts of the machine are connected on the frame in alignment.
- 2. Feeding unit** is hopper with movable gate to control the amount of eggplant flow rate from the hopper. The hopper has dimensions of $100 \times 65 \times 34$ cm for length, width and height respectively. The hopper slope angle gradually to allow sliding of eggplant and keep continuous flow at constant rate from hopper to rotary brushes unit. The hopper is supported at the frame with screw bolts.
- 3. Cleaning unit contains 4 cylinder brushes.** The four brushes act as impurity separators. Each brush is of 47 cm length and 7.5 cm diameter.
- 4. Grading unit having six cylinders.** Each cylinder is of 47cm length and 7.5 cm diameter. The distance between the cylinder can adjusted according the grading vegetable size. Grading unit having 6 cylinders with inter spacing. This spacing can be regulated under grading to receive the graduated eggplant.
- 5. Power transmission**

The power transmission of grading machine consists of two motions; the first to vibrate the machine frame. This motion supply from the motor have 0, 18 kW. The pulley with 100 mm diameter fixed on the motor shaft. The second motion was done to rotate the grading cylinders. Using a motor having 0, 63 kW. The drive gear is connected on the motor shaft as shown in figure (3).

Experimental conditions

The experiments were designed and carried out to study the effect of the following variables:

- 1- Three different drum speed of grading unit (0.31; 0.41; 0.59) m/sec.
- 2- Four different grading slope angle of grading unit (0.0; 1.0; 2.0; 3.0 deg.) with three receiving units.

Experimental procedure

The eggplant was let to pass on the cleaning unit to improve the product appearance and edibility and then,

dropped from the cleaning unit to the grading unit. The grading unit having six cylinders and gate having six receiving unit the distance between cylinders calculate

from physical properties were used to receive the graduated eggplant by shape and size.

No.	Part name
1	Main frame
2	Hopper
3	Hopper gate
4	Cleaning unit
5	Grading unit
6	Receiving unit
7	Receiving cover
8	Gear box covers
9	1 st Electric motor
10	2 nd Electric motor

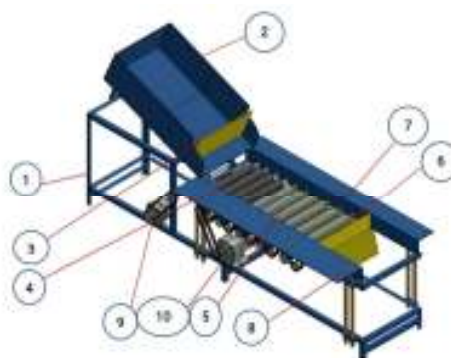

Fig. 1. An isometric of proposed machine

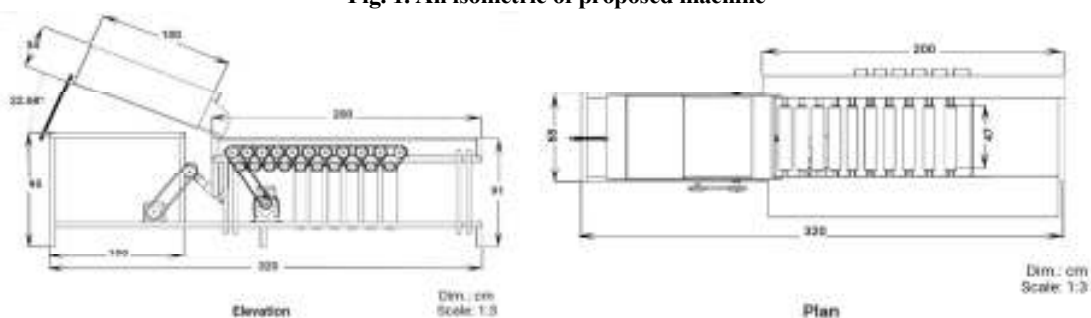

Fig. 2. Schematic diagram of the grading machine

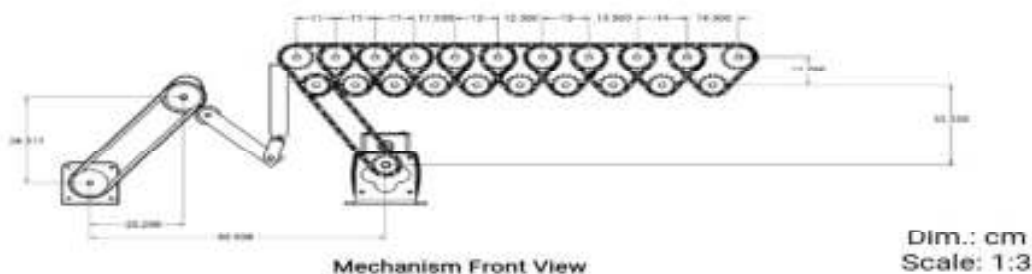

Fig. 3. The transmission system of the machine

Measurements

Fruit principal dimensions

A sliding caliper accurate ±0.01 mm was used to measure fruit length (L) and greatest diameter (D). Sphericity was then calculated according to Mohsenin, (1986) as follows:

$$S = \text{Length} / \text{Diameter} \dots\dots (1)$$

If the sphericity (S) is less than 0.9, that means the fruit belongs to the oblate group. If sphericity (S) is greater than 1.1, that means the fruit belongs to the oblong group.

Measurements of fruit mechanical properties

a. Eggplant firmness

The fruit firmness was measured for eggplant using a portable hand-held tester (Taylor Pressure tester) the firmness apparatus and penetrates the fruit texture by apparatus cone and recording the fruit firmness.

b. Coefficient of friction

Coefficient of friction for eggplant was measured under the conditions of one surface nickel chrome (3 mm

thickness) by placing the eggplant one by one on the horizontal surface of the inclined plane and gradually increasing the angle of surface inclination.

c. Impact heights of eggplant

Impact heights of eggplant were conducted by free fall dropping of the sample from height on Nickel chrome surface (3 mm thickness).

Measurements of mechanical damage

The mechanical damage of eggplant crop has calculated according to Mcgechan, (1980) as:

$$M_{\text{dam}} = \frac{m_1 - m_2}{m_1}, \% \dots\dots (2)$$

Where:

m₁ = Total mass before all treatments, kg,

m₂ = Total mass after treatments (undamaged fruits), kg.

The amount of damage for eggplant was determined based on the surface damage and internal bruising.

Machine grading capacity and efficiency

The grading capacity for the developed grading machine was determined according to Amin, (1994) as:

$$W = m_i \times \frac{60}{t} \dots\dots\dots (3)$$

Where:

W= Grading capacity of the machine in ton/h,
 m_i = Mass of classified fruits from any unit (i) in ton,
 t = Grading time in min.

The total machine grading efficiency of the machine was estimated using the following formula:

$$\eta_0 = \frac{m_1 + m_2 + m_3 + m_4}{m} \times 100 \dots\dots\dots (4)$$

Where:

η₀ = Total machine grading efficiency %,
 m = Total mass of fruits in ton,
 m_{1,2,3,4} = Averaged means difference sizes (small, medium and big in kg).

Estimation of specific energy consumption

The specific energy consumption (S.E.C.) in kW. h /ton was calculated by using the following equation:

$$S.E.C. = Power/ Capacity, kW. h/ ton \dots\dots\dots (5)$$

Where:

S.E.C. = Specific energy consumption, kW. h/ ton,
 P= Power requirement to doing the handling process for fruits, kW,
 C= Capacity of the handling machine, ton/h.

Cost evaluation for the developed grading machine

In this study two parameters were calculated as the absolute total cost including both fixed and variable costs per hour according to (ASAE, 2001) and price level of 2017.

$$Total\ operation\ costs\ (LE / h) = Fixed\ costs\ (LE / h) + variable\ costs\ (LE / h) \dots\dots\dots (6)$$

$$Total\ productivity\ cost, (LE/ ton) = total\ operation\ costs, LE/h / capacity\ (optimum), ton/h \dots\dots\dots (7)$$

RESULTS AND DISCUSSION

1- Physical principal dimensions

Data in table (1) shows some of the physical properties of the Baladi eggplants variety eggplant.

Table 1. Maximum, minimum, average, standard deviation and coefficient of variation of length (mm), diameter (mm), volume (cm³) and sphericity of the studied eggplants:

Variety	Feature	length, mm	Diameter, mm	Volume, cm ³	Sphericity
Baladi eggplant	Max	78.43	45.18	785.23	1.36
	Min	127.99	54.46	1613.1	2.38
	Av	165.25	72.97	2853.87	3.47
	± SD	19.57	6.25	463.98	0.44
	CV %	8.45	11.68	6.15	7.82

From the data listed in Table (1), and with respect to the sphericity as shown in figure (4), it is clear that the sample of the eggplant were described as oblong variety. These result help in designing of the hopper gate to control eggplant feeding rate, division of samples into categories and determine the suitable distance between rolling to complete the grading process.

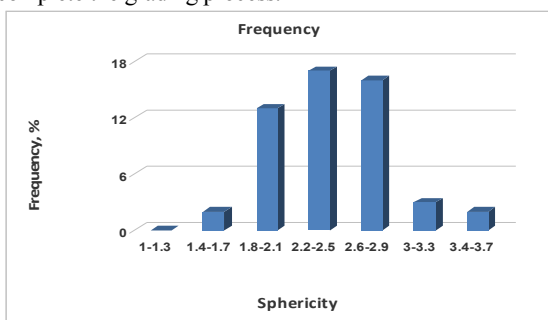

Fig. 4. Frequency of sphericity for Baladi eggplants variety eggplant

2-Mechanical properties

The mechanical properties of the studied variety of eggplant listed in Table (2).

Table 2. Mechanical properties of the studied variety of eggplant:

variety	Impact		Friction	Firmness, kg	
	Drop height, m	Pf, N.m	slope angle, deg. Nickel.	Surface, kg Average	without the crust, kg Average
Baladi eggplant	0.34	76.636	22.68°	5.6 ± 0.67	4.5 ± 0.6
	0.38	85.652			
	0.42	94.668			

The results indicated that the maximum and minimum impact height causing no damages. The results show that, the nickel chrome surface gave the values of friction coefficient of 0.42 m. The angle is calculated from the best height allowing the eggplant to roll easily. The angle of surface inclination of 22.68 degree. Firmness for surface is 5.6 kg for eggplant.

3-Machine performance evaluation for Baladi eggplants variety eggplant

These experiments which were carried out on the developed machine to evaluate performance of machine included productivity, grading efficiency and total mechanical damage and as effected by drum speed (m / s) and grading slope angle (deg.).

1- Capacity of the developed grading machine for Baladi eggplants variety eggplant

Increasing drum speed from 0.31 to 0.59 m / s caused to increase machine grading capacity. Drum speed of 0.41 m / s tends to increase grading capacity to 3.4 ton / h at grading slope angle (0.0 deg.) as shown in figure(5).

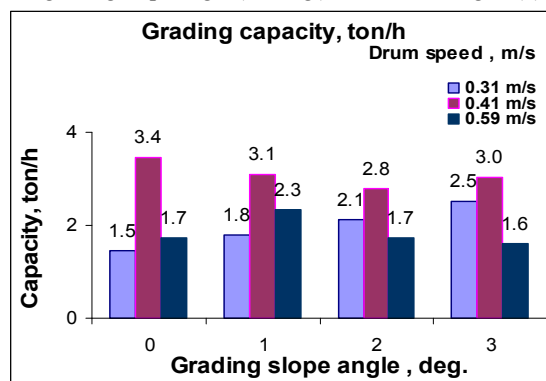

Fig. 5. Effect of drum speed and grading slope angle on grading capacity for Baladi eggplants variety eggplant

2-Grading efficiency of the developed grading machine for Baladi eggplants variety eggplant

a. Effect of grading slope angle

Increasing grading slope angle from 0.0 to 3.0 deg. caused to increase machine grading efficiency. Drum speed of 0.41 m/s tends to increase grading efficiency to 84.6% at grading slope angle of 2.0 deg. as shown in figure (6).

b. Effect of Drum speed

Increasing Drum speed from 0.31 to 0.59 m/s caused a corresponding increase machine grading efficiency. Drum speed of 0.41 m/s tends to increase grading efficiency to 84.6% at grading slope angle of 2.0 deg. as shown in figure (7).

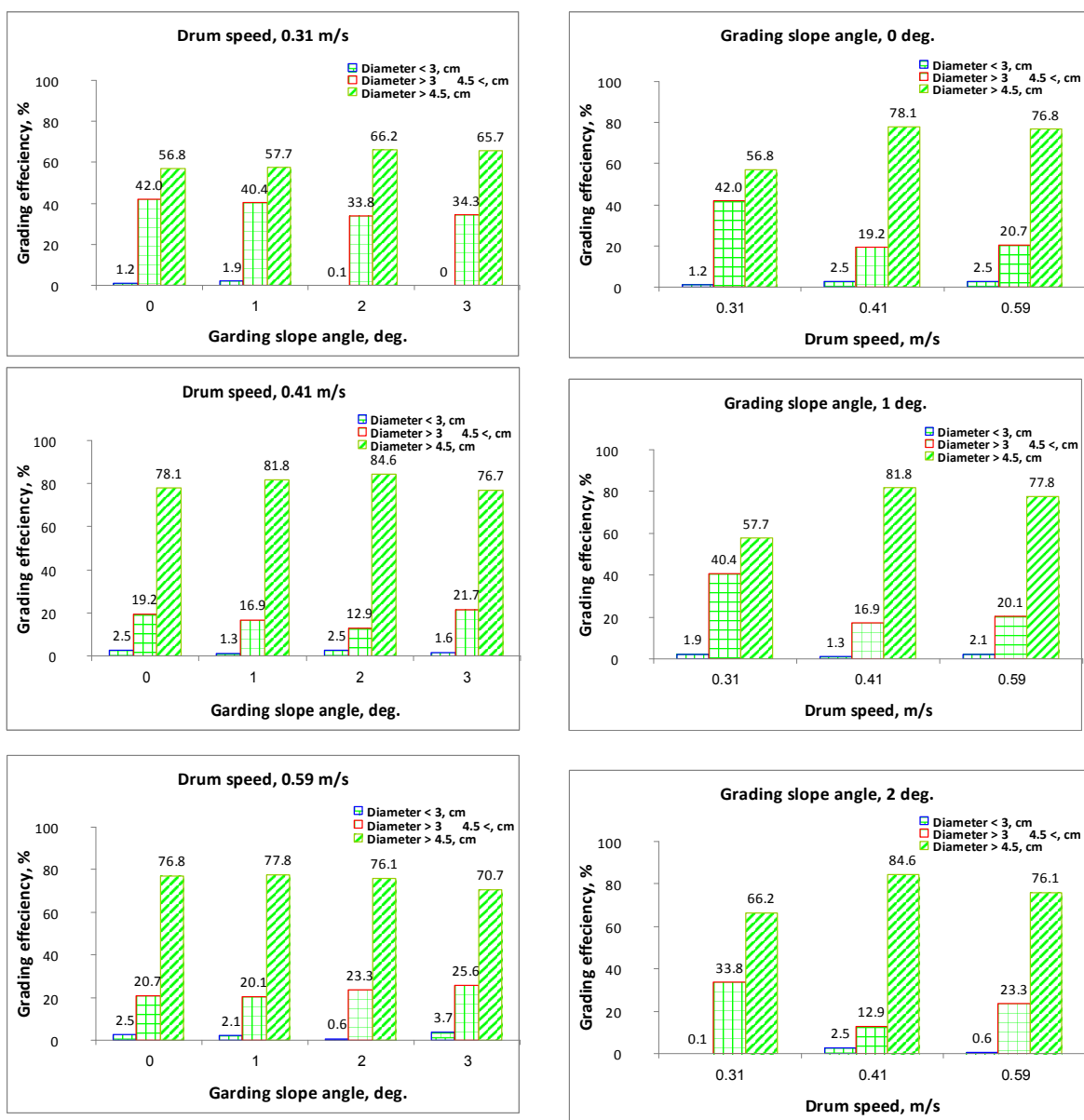

Fig. 6. Effect of grading slope angle on grading efficiency for Baladi eggplants variety eggplant

4- Mechanical damage of the eggplant for Baladi eggplants variety eggplant

Increasing the Drum speed from 0.31 to 0.59 m/s caused a corresponding decrease mechanical damage of machine. Drum speed of 0.59 m/s tends to decrease the damage index to 5.08% at grading slope angle of 3.0 deg. during grading processes as shown in figure (8).

5- Power and energy requirements for Baladi eggplants variety

The highest specific energy consumption was recorded using highest rotating speed of drum 0.59 m/sec which was 0.52 kW. h /ton at grading slope angle (3 deg.) while the lowest specific energy consumption was recorded using lowest rotating speed of drum 0.31 m/sec which was 0.32 kW.h/ton at grading slope angle (3.0 deg.) as shown in figure. (9).

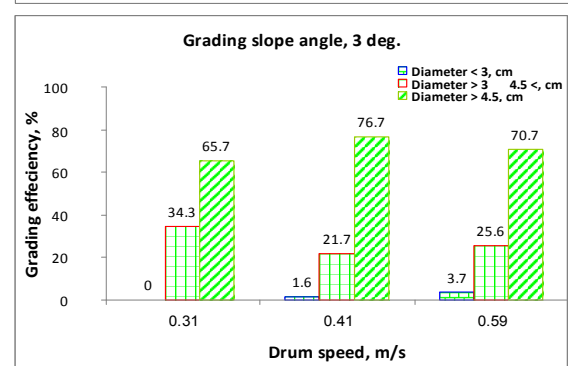

Fig. 7. Effect of drum speed on grading efficiency for Baladi eggplants variety eggplant

6- Cost estimation for the developed grading machine

Data in table (3) evident that the mechanical grading needed the lowest labour time (h/ton) while the higher labour time was obtained when the work was done

manually. For it can be seen that using mechanical method for grading needed 0.4 h/ton. While the conventional grading method needed one hour per ton by using (10) workers. On-the other words, the labour time (h/ton) of manual grading is about 3.4 times larger than that using mechanical grading.

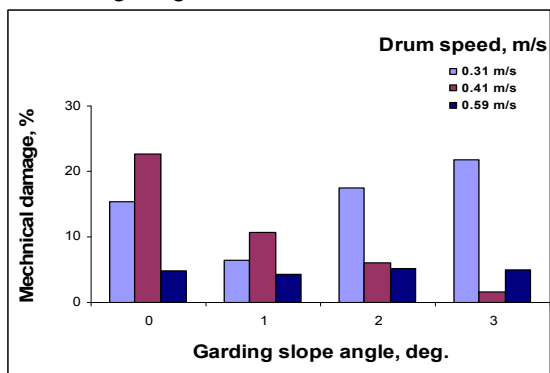

Fig. 8. Mechanical damage caused by the grading unit for Baladi eggplants variety eggplant

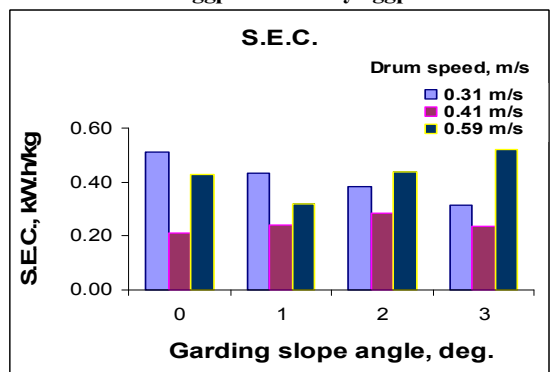

Fig. 9. Effect of drum speed and different slope angle deg. on the SEC for grading machine of Baladi eggplants variety eggplant

Table 3. Cost estimation for the developed grading machine:

No.	Items	Cost
1	Total fixed costs, (LE/h)	2.128
2	Variable costs:	
3	Repair and maintenance, (LE/h)	1.44
4	Electric energy cost, (LE/h)	0.46
5	Labour cost, (LE/h)	15
6	Grease and daily services, (LE/h)	0.08
7	Total variable costs, (LE/h)	16.98
8	Total operation cost, (LE/h)	19.108
9	The total productivity cost, (LE/ton)	5.62

CONCLUSION

The developed grading machine has good performance data in eggplant grading process with different factors under study. The optimum operating parameters for developed grading machine were drum speed of 0.41 m/sec and grading slope angle of 2.0 (deg.). At these levels maximum grading efficiency 84.6%, damage index of 5.08%, specific energy consumption of 0.32 kW. h / ton and total productivity cost of 5.62 LE / ton for Baladi eggplant variety.

REFERENCES

- Amin, E. A., (1994) "Development of grading machine for some Egyptian farm crops ", J. Agric. Sci., Mansoura Univ., Vol 19 (7): (2398 - 2411).
- ASAE Yearbook Standard, (2001)"Agricultural engineers' year-book", ASAE.St. Joseph, MI., 49085-9659, USA.
- Buyanov, A. I. and B. A., Voronyuk, (1985) "Physical and Mechanical Properties of Plants, Fertilizers and soils", Amerind publishing Co. Pvt. Ltd. New Delhi-Bombay-Calcutta-New York
- FAO, (2018), <http://chartsbin.com/view/39421>.
- Ibrahim, M.K.E., (1982)" Wet milling wheat grain", M.Sc. Th., Fac. of Agric. Mansoura Univ. :64 - 65.
- Mcgechan, M. B., (1980) "An investigation into the damage sustained by different varieties of potatoes during riddling to removal soil", J.Agric. Eng.res. v.25, n. 4, p. 345-353.
- Ministry of Agricultural and Land Reclamation Economic Affairs Sector, (2015)" Bulletin of an Agric Statistics", part (2) summer season and Nile crop.
- Mohsenin, N.N., (1986) "Physical properties of plant and Animal Materials. Gordon and Breach Science Publishers", p. 20 - 89.
- Prasad, B., (2015)" Postharvest analysis of vegetables in fiji eggplant, okra and tomato", M. S. Thesis, The University of the South Pacific, 2015.
- Taher, D.; S. Ø., Solberg; J., Prohens; Y., Chou; M., Rakha and T.,Wu,(2017)"world vegetable center eggplant collection: origin, composition seed dissemination and utilization in breeding", world vegetable center eggplant collection ,Vol (8),Article 1484.
- Ukey, P. D. and P., Linde, (2010) "Design, development and performance evaluation of sapota fruit grader", International Journal of Agricultural Engineering, Vol 3 (1): 35-39, 62-64.
- United States Standards for Grades of Eggplant, (February 4, 2013), https://www.ams.usda.gov/sites/default/files/media/Eggplant_Standard%5B1%5D.pdf.

تطوير آلة لتدريج الباذنجان

عماد الدين أمين عبد الله ، طارق حسني الشبراوي و شيماء إبراهيم عبد القادر
قسم الهندسة الزراعية – كلية الزراعة – جامعة المنصورة

تم تصنيع وتطوير الآلة في ورشة بميت على في المنصورة لتدريج الثمار البستانية على أساس كروية الشكل لتتناسب ظروف العمل في محطات التداول ومصانع الأغذية الصغيرة. وقد تمت الدراسة على النحو التالي: (1) دراسة الخواص الطبيعية والميكانيكية لثمار الباذنجان لتحديد العوامل التصميمية للآلة. (2) دراسة العوامل الميكانيكية لتشغيل الآلة. وقد شملت الدراسة المتغيرات التالية: 1: ثلاث سرعات دورانية مختلفة لوحدة الدرجات (0.31; 0.41; 0.59) م / ثانية. 2: أربعة ميول مختلفة من وحدة التدريج (3.0; 2.0; 1.0; 0.0) درجة مع 3 وحدات استقبال. هذا وقد تم اختبار وتقييم أداء وكفاءة آلة التدريج المصنعة محليا تحت ظروف التشغيل المختلفة. مع تقدير احتياجات آلة التدريج المصنعة محليا من الطاقة وتقدير التكاليف لآلة التدريج المصنعة محليا. ويمكن تلخيص أهم النتائج هذه الدراسة في النقاط التالية: 1. أكبر سعة تدريج أمكن الحصول عليها بنسبة 3.4 طن / ساعة وذلك باستخدام السرعة الدورانية 0.41 متر / ثانية. 2. بزيادة ميل التدريج من 0.0 إلى 3.0 درجة يؤدي إلى زيادة كفاءة التدريج عند السرعة الدورانية 0.41 متر / ثانية بنسبة 84.6%. 3. السرعة الدورانية 0.59 متر / ثانية تؤدي إلى خفض مؤشر التلف للثمار بنسبة 5.08% عند ميل 3 درجة. 4. أعلى استهلاك للطاقة النوعية سجل عند أعلى سرعة دورانية وهي 0.59 متر / ثانية بنسبة 0.52 كيلو وات ساعة/طن بينما أقل استهلاك للطاقة النوعية سجل عند أقل سرعة دورانية وهي 0.31 متر / ثانية بنسبة 0.32 كيلو وات ساعة / طن. 5. تبلغ إجمالي تكاليف العملية للطن الواحد 5.62 جنيه / طن عند السرعة الدورانية 0.41 متر / ثانية. 6. العوامل المثلى لتشغيل لآلة التدريج المطورة كانت باستخدام ميل التدريج 2.0 درجة و السرعة الدورانية 0.41 متر / ثانية حيث أعطت أعلى كفاءة تدريج بنسبة 84.6% ، ونسبة تلف مسموح بها إلى 5.08% ، وكان استهلاك الطاقة المحددة 0.32 كيلوات ساعة / طن والتكاليف الإجمالية للطن الواحد 5.62 جنيه / طن للباذنجان صنف البلدي.