

TRANSMISSION LINE ENERGISATION TRANSIENTS
A CASE WITH STEEP FRONTS AND SPIKES

BY

Reda M. K. El-Dewieny

ABSTRACT:

The magnitudes and waveforms of overvoltages produced by the energisation operation of a transmission line depend, among other factors, on the source-side circuit configuration, line trapped charge, and pre-insertion resistors. This paper investigates the effects of these three factors in case of steep fronts and severe spikes appear in the overvoltage waveform obtained at the remote end of the energised line. Computer study is reported and the results show that the steep fronts and spikes are largest when trapped charge is present.

1. INTRODUCTION:

Transmission line energisation is an operation which causes a transient overvoltage¹⁻⁴ at the remote end of the line due to voltage doubling which occurs at an open circuit. In order that the system insulation level may be optimised, for power transmission networks with operating voltage^{5,6} in excess of 400 kV, it is necessary to know not only the magnitude of these overvoltages, but also to determine their waveforms and their degree of severity. The latter is important in choosing the appropriate protection devices associated with the system^{7,8}.

Although basically it is a voltage doubling which occurs when an open-circuited line is energised, it is found in practice that other factors exist which modify the magnitudes and waveforms of the overvoltages obtained. Previous work^{1,3,4,6} in this field has shown that these factors include the c

The author is a lecturer at the Department of Electrical Power and Engineering, Faculty of Engineering, University of El-Mansoura.
Mansoura Bulletin, June 1979.

1
Mr. T. H. El-Dewieny
1979

1.78. El-Dewieny

between the phases of the three-phase line, nonsimultaneous closure of the three poles of the circuit breaker, the presence and rate of decay of trapped charge voltage on the line, as well as the configuration of the source-side circuit from which the line is energised. These factors may combine to such an extent that it is possible for the overvoltage to exceed twice the normal voltage by a considerable margin and to cause its waveform to contain steep fronts and severe spikes.

This paper investigates the influence on both magnitude and waveform of the energisation overvoltage, received at the remote end of a line, due to the following factors

- (a) Configuration of the source-side circuit,
- (b) Trapped charge on the line being energised, and
- (c) Circuit-breaker pre-insertion resistors.

The investigation is carried out using a digital computer program based on the travelling wave equations of a transmission line being, an extension of the lattice diagram method due to Bowley⁹. The program is described briefly in Ref. 7 and in detail in Ref. 10.

2. SYSTEM REPRESENTATION:

Fig.1 shows the system¹¹ under consideration. The line to be energised is of length 265 km. The source side consists of a 380-kV source (source 1) in series with a double-circuit line of length 150 km, all in parallel with another 380 kV source (source 2). Each source consists of a generating station and an Auto-transformer which raises the voltage at the switching busbar (B) to 1050 kV. The double-circuit line is connected between busbars A and B, as shown.

2.1 Generators and Transformers:

Both of the generators are identical and each has a short-circuit level of 30 GVA at 380 kV with unity zero-sequence to positive-sequence reactance ratio.

The two transformers are the same. Each of them is a 380/1100 kV, 2000 MVA, Auto-transformer equipped with a tertiary coil. Referred to 2000 MVA base, the transformer inductances are:

$$r_1 = 12\% \quad , \quad X_{H-T} = 32\% \quad \text{and} \quad X_{L-T} = 20\%$$

T denote high tension, low tension, and tertiary, respectively.

From these data, the inductance of the combined generator and transformer of each source is calculated as 0.2215 H.

2.2 Transmission Lines:

The overhead double-circuit line feeding the switching busbar has the following positive and zero sequence, 50 Hz constants for each circuit:

$R_1 = 0.0079$	ohm/km	$R_0 = 0.0824$	ohm/km
$X_1 = 0.2593$	ohm/km	$X_0 = 0.604$	ohm/km
$C_1 = 14.14$	nF/km	$C_0 = 9.96$	nF/km

Considering the line natural frequency ($=3 \times 10^8 / 4 \times 256 \times 10^3 \approx 300$ Hz) and taking into account the dimensions of the line towers, the surge impedance matrix of the energised line is calculated at 100 ohm-meter earth resistivity as

$$Z_c = \begin{bmatrix} 330.8 & 70.0 & 35.2 \\ 70.0 & 329.0 & 70.0 \\ 35.2 & 70.0 & 330.8 \end{bmatrix}$$

The transmission lines are represented throughout the investigation as untransposed (a case which usually exists in practice) and the losses of the energised line are included in the calculations.

2.3 Circuit Breaker:

Each of the circuit breaker poles has a pre-insertion resistor^{1,3,10} of 300 ohms and is therefore equipped by two contacts, as shown in Fig.2.

In all switching operations, the points-on-waves switching^{4,10} of the circuit breaker poles, referred to the point of phase-to-ground voltage zero with positive dv/dt of the first phase to close (Phase R) are:

	contact 1	contact 2
Phase R	41° 30'	167° 30'
Phase Y	102°	229° 30'
Phase B	102°	228° 30'

This means that for contacts 1 of all phases, that of phase R closes at a point 41° 30' after the point of zero phase-to-ground voltage of the R phase; those of the Y and B phases close simultaneously but 60° 30' after contact 1 of phase R closes. Contacts 2 of the R, B and Y phases close at instants 126°

E.80. El-Dewieny

187°, and 188°, respectively after contact 1 of phase R closes.

2.4 Line Trapped Charge:

Whenever present, the values of trapped charge on the phases of the energised line, in p.u. of phase-to-ground peak voltage ($\sqrt{2} \times 1050/\sqrt{3}$ kV) are:

$$\text{Phase R} = -1$$

$$\text{Phase Y} = +1$$

$$\text{Phase B} = +1$$

3. RESULTS:

Overvoltage magnitudes and waveforms are obtained at the receiving end (R.E.) of the line being energised. Results are obtained for the system as described in Section 2 above. In addition, results are obtained with alterations to the circuit on the source side and with no pre-insertion resistors and also with no trapped charge on the line being energised.

Table 1 gives the maximum receiving end voltage obtained on each phase. The resulting overvoltage waveforms are given by Figs. 3 to 8. Details of the cases considered are given below. In all cases the switching instants are as given in Subsection 2.3 and the overvoltage values are also expressed in p.u. as the trapped charge.

3.1 Case 1: System as defined in Section 2:

This is the system given by Fig.2. In this case there are trapped charges on the line phases having the values given in Subsection 2.4. The receiving end voltage waveforms of the three phases are shown in Fig. 3(a), 4, and 5. It can be seen that the highest voltage is due to the spike on phase R and has a value of 2.30 p.u.

3.2 Case 2: Source 1 and Transformer 1 disconnected:

With source 1 and transformer 1 disconnected from the system the 150 kV double-circuit line on the source side is left open circuited at busbar 1. It is found that, this does not alter drastically the waveform of the receiving end voltage on phase R but causes an increase in the maximum overvoltage, given by the spike, to 2.42 p.u.

3.3 Case 3: Source 2 and Transformer 2 disconnected:

The system is as in Case 1 but with source 2 and transformer 2 disconnected from busbar B. Again this causes relatively small changes to the waveform of the phase R receiving end voltage while an increase appears in the spike voltage to 2.45 p.u.

3.4 Case 4: No Transmission Lines on the Source Side:

In this case the 150 km double-circuit line on the source side is removed and source 1 and transformer 1 are connected to busbar B together with source 2 and transformer 2. This has the effect of changing the waveform of phase R receiving end voltage but a spike of magnitude 1.93 p.u. is still present. The waveform is shown in Fig.6.

3.5 Case 5: Only one Circuit of the double-circuit line on the Source Side:

Under the conditions of one 150 km circuit of the double-circuit line out of service, the waveform of the receiving end voltage of phase R is shown in Fig.7(a). It can be seen that the spike is reduced and has a value of 1.81 p.u. With no trapped charge on the energised line, the receiving end voltage waveform is as shown in Fig.7(b). The effect is a further reduction in the spike to about 1.28 p.u. This value is still the maximum overvoltage obtained at the R.E. of the line.

3.6 Case 6: No pre-insertion Resistors:

The system is as in Case 1 with the exception that no pre-insertion resistors are used. Fig.8(a) shows the receiving end voltage waveform of phase R. It can be seen that, as a result of the removal of the damping due to the pre-insertion resistors the spike does not appear to be as prominent. Its magnitude is 3.08 p.u. but is no longer the maximum overvoltage which now occurs. In this case it is on phase Y and has a value of 3.19 p.u.

3.7 Case 7: No trapped Charge:

As is to be expected, without trapped charge on the energised line the receiving end voltage of phase R, as well as of the other phases, is reduced. The reduction in the magnitude of the spike is however greater than that of the remainder of the waveform as may be seen from Fig. 3(b). Nevertheless, the spike still gives the maximum overvoltage and its value is 1.49 p.u.

E. 82. El-Dewieny

3.8 Case 8: No trapped Charge and no pre-insertion Resistors:

With no trapped charge on the energised line and without pre-insertion resistors the waveform of the Phase R receiving end voltage is shown by Fig. 8, curve (b). It is shown that, under these conditions the spike is not particularly noticeable although it still gives the maximum voltage which is 1.84 p.u.

4. CONCLUSIONS:

The results of this investigation concludes that the steep fronts and the severe spikes appearing in the receiving end voltage waveforms, are largest and most pronounced when trapped charge is present on the line being energised. To a lesser extent, the presence of the double-circuit line on the source side accentuate the spikes due to the reflections from its far end. The pre-insertion resistors generally reduce the spikes, and consequently the overvoltage magnitudes, because of their damping effect on the oscillations caused by reflections from the ends of the lines. Their presence however does make the main spike appear more prominent.

Although intensive and considerable work¹² concerning energisation transients of open-circuited transmission lines have been carried out the results of this investigation emphasize that, for reliable design and operation of transmission networks, switching overvoltage studies for some individual cases may be of necessity.

5. REFERENCES:

1. J.P. Bickford and P.S. Doepel: "Calculation of Switching Transients with particular Reference to Line Energisation". Proc. IEE, Vol.114, No.4, April 1967, p 465.
2. M.T. Battison, J.P. Bickford, J.C.W. Corcoran, R.L. Jackson, M. Scott and R.J.S. Ward: "British Investigations on the Switching of long EHV Transmission Lines". CIGRE Report No. 13-02, 1970.
3. J.P. Bickford and R.M.K. El-Dewieny: "Energisation of Transmission Lines from inductive Sources- Effects of non-simultaneous Closure also investigated". Proc. IEE, Vol.120, No.8, August 1973.

4. J.P. Bickford and R.M.K. El-Dewiemy: "Energisation of Transmission Lines from mixed Sources". Proc. IEE, Vol.121, No.5, May 1974.
5. A. Haupturg, G.S. Vassell, G.I. Stillman, J.H. Charkow and J.C. Haahr: "Overvoltages on the AEP 765-kV System". IEEE Trans., PAS, Vol.88, September 1969, pp 1329-1342.
6. J.K. Dillard, J.M. Clyton and L.A. Kilar: "Controlling Switching Surges on 1100 kV Transmission Systems". IEEE Trans., PAS, Vol.89, Nov./Dec. 1970, pp 1752-62.
7. R.O. Caldwell and M. Darveniza: "Experimental and analytical Studies of the Effect of non-standard Wave shapes on Impulse strength of external Insulation". IEEE Trans., PAS-92, 1973, pp 1420-1428.
8. IEC Publication 71: "Insulation Coordination". Fifth Edition, 1972, and Supplement dated Nov. 1975.
9. L.V. Bewley: "Travelling Waves on Transmission Systems". Wiley, 1951.
10. J.P. Bickford: "Investigation into the Use of Resistors for the Reduction of Switching Overvoltages with particular Reference to Line Energisation". Ph.D. Thesis, C.N.A.A., U.K. , 1968.
11. A. Clerici and A. Tashini: "Influence on Switching Surges of the switched Line Zero Sequence Impedance". IEEE Trans., PAS, Vol.90, May/June 1971, pp 1327-1333.
12. R.M.K. El-Dewiemy: "The Effect on Energisation Overvoltage Magnitude of the Type of Source and Circuit Breaker Non-simultaneous Closure". Ph.D. Thesis, University of Strathclyde, Glasgow, U.K. , April 1974.

B.84. El-Dewieny

Table 1. Maximum Receiving End Voltage (p.u.)

Case No.	Fig. No.	Phase R	Phase Y	Phase B
1	3, 4, 5	2.23	1.51	1.58
2	—	2.42	1.46	1.56
3	—	2.45	1.50	1.68
4	6	1.93	1.34	1.44
5	7	1.81	1.47	1.50
6	8(a)	3.08	3.19	2.72
7	3(b)	1.49	1.18	1.24
8	8(b)	1.84	1.75	1.82

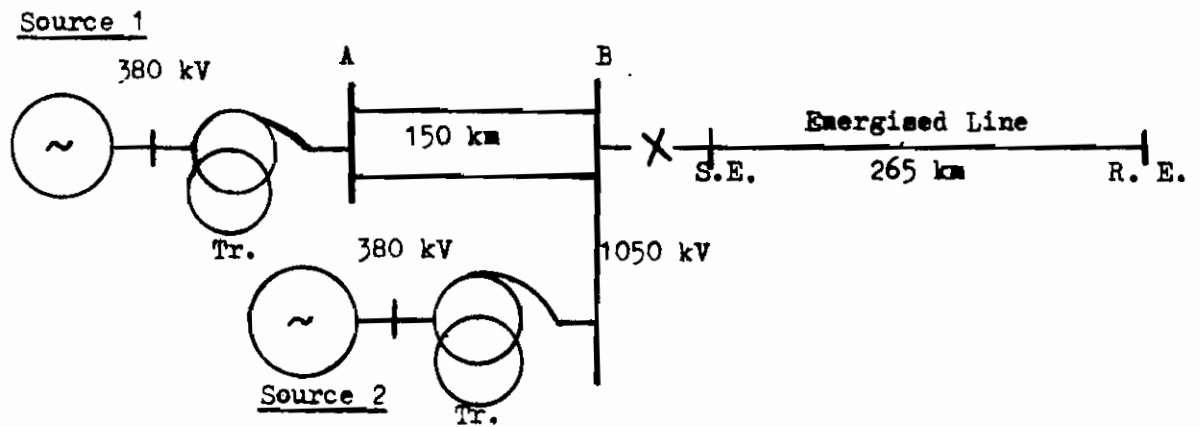

Fig. 1 : Single line diagram of the system studied.

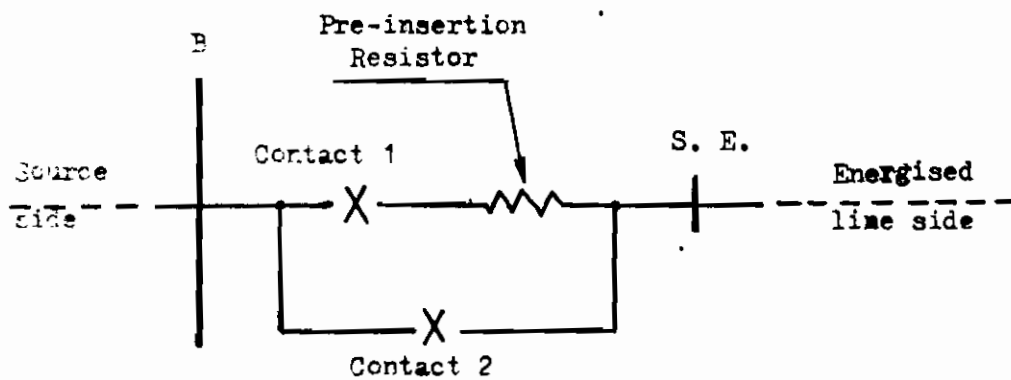

Fig. 2 : Single-phase representation of the Circuit Breaker Poles.

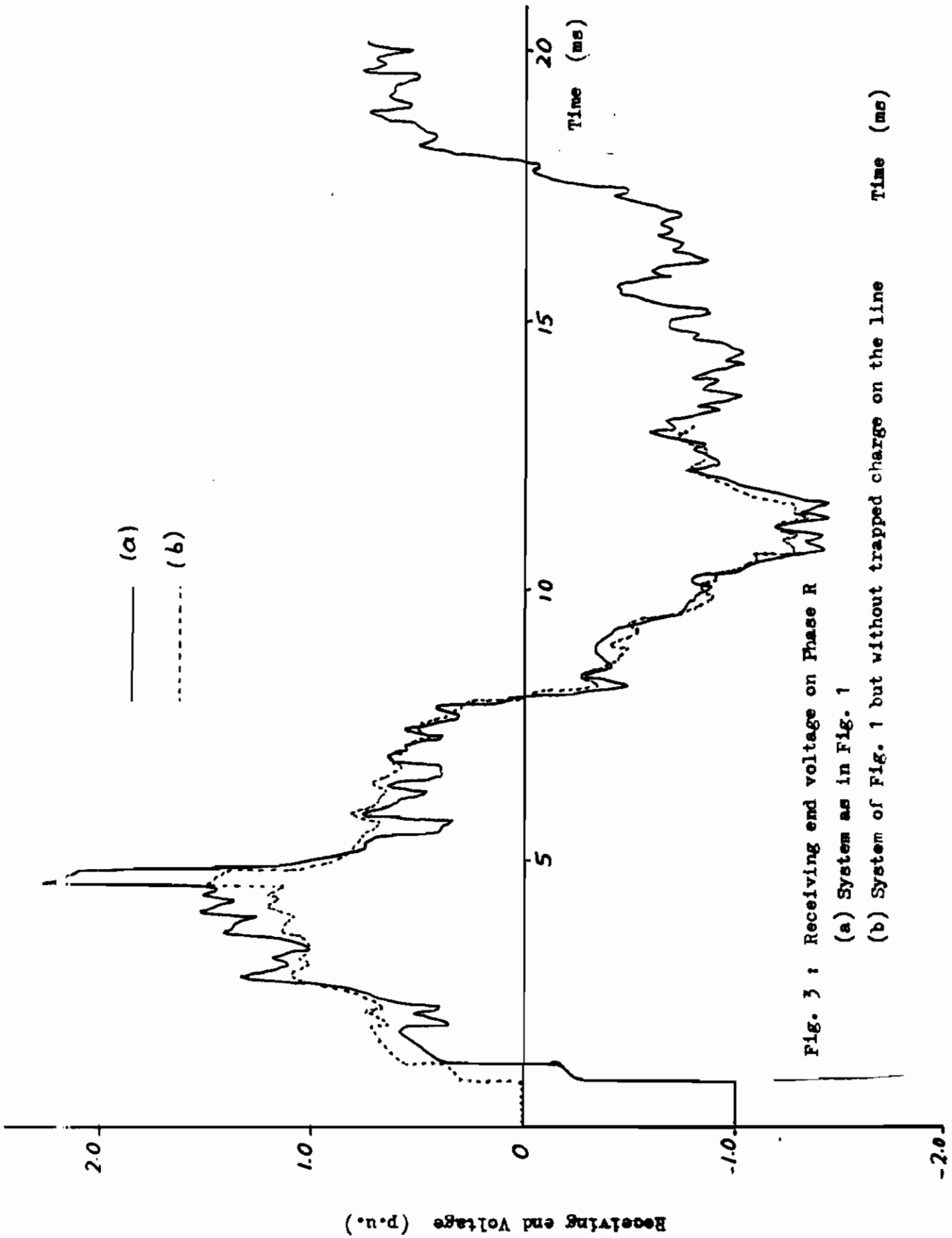

Fig. 3 : Receiving end voltage on Phase R

(a) System as in Fig. 1

(b) System of Fig. 1 but without trapped charge on the line

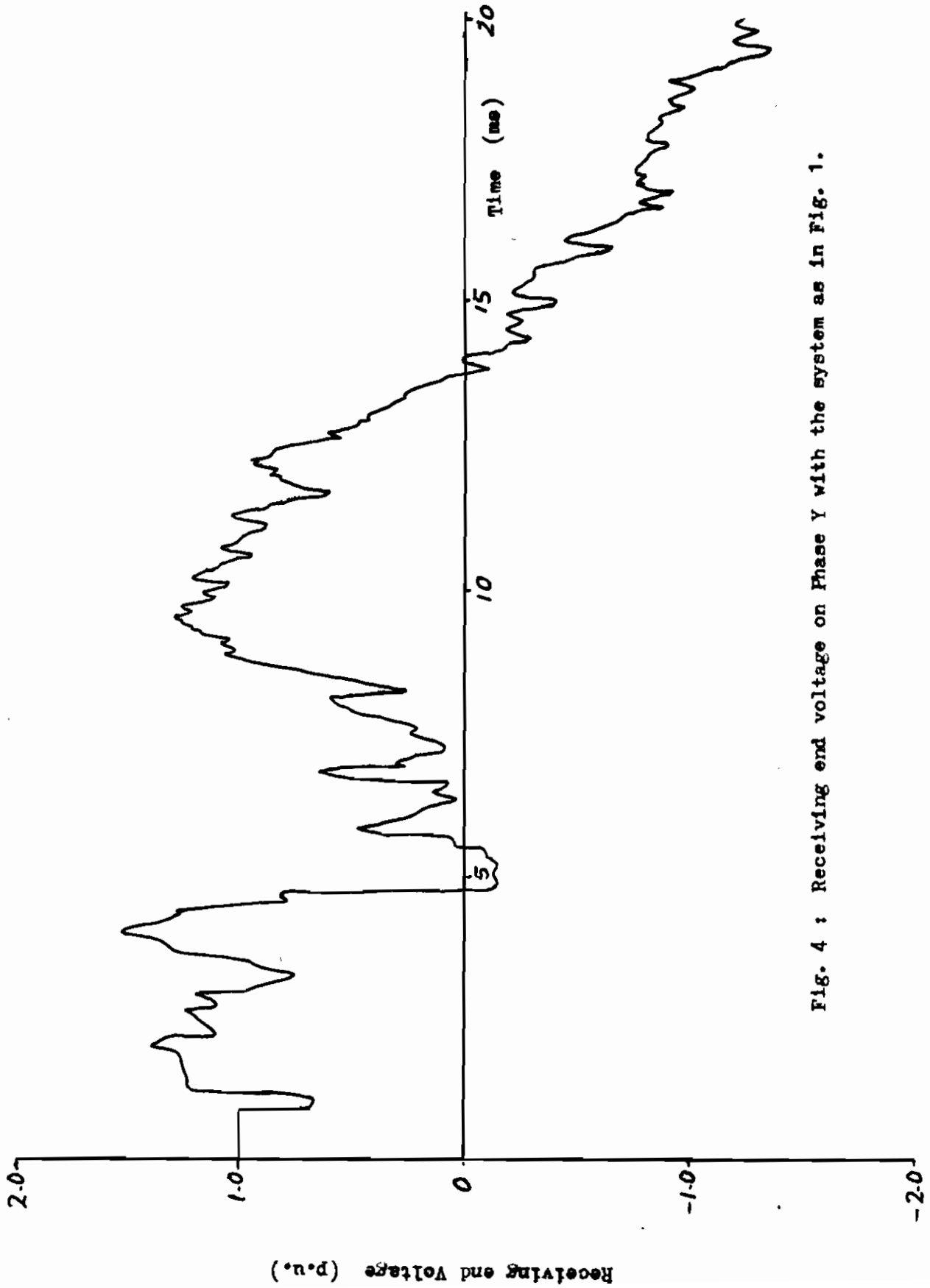

Fig. 4 : Receiving end voltage on Phase Y with the system as in Fig. 1.

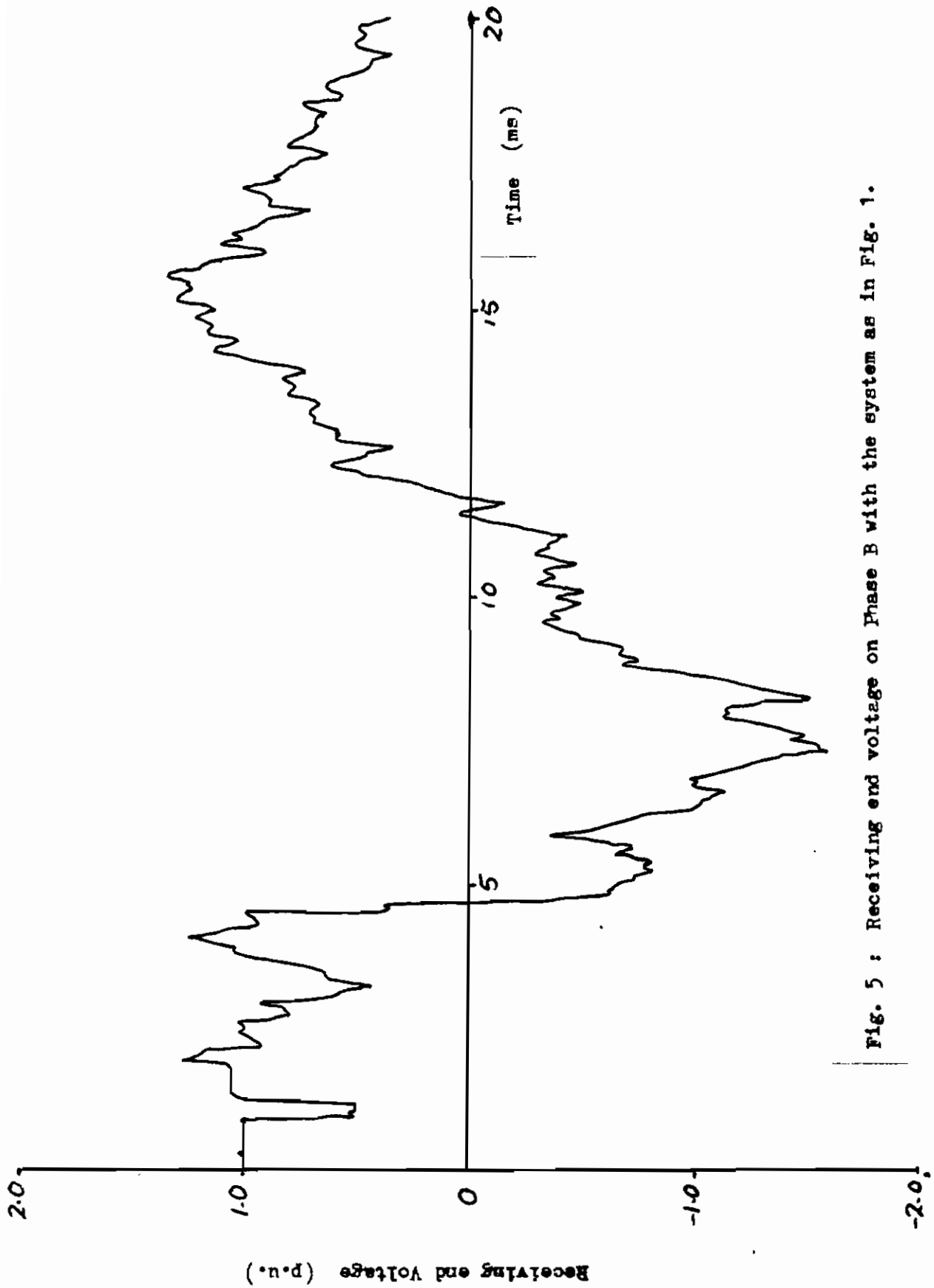

Fig. 5 : Receiving end voltage on Phase B with the system as in Fig. 1.

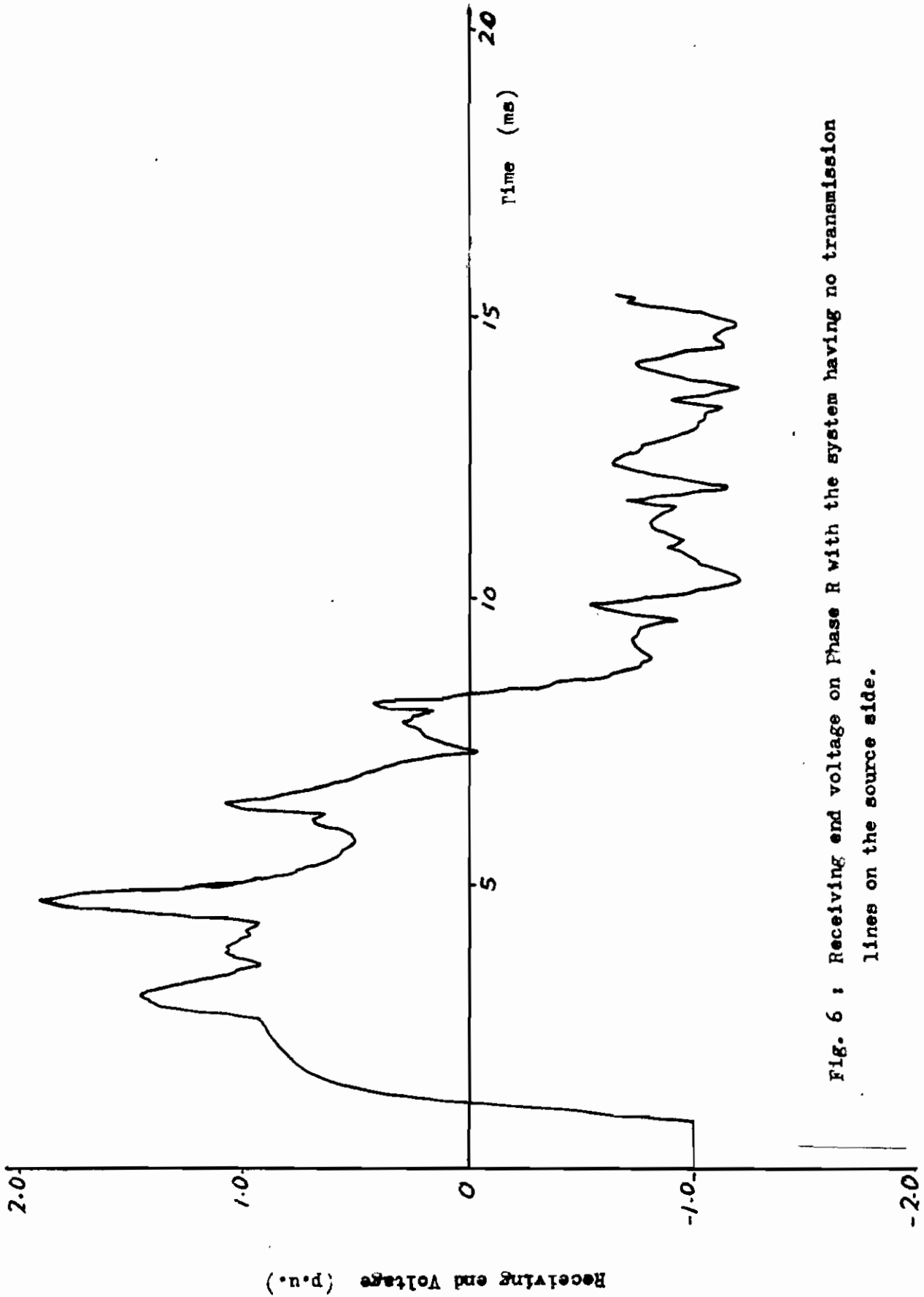
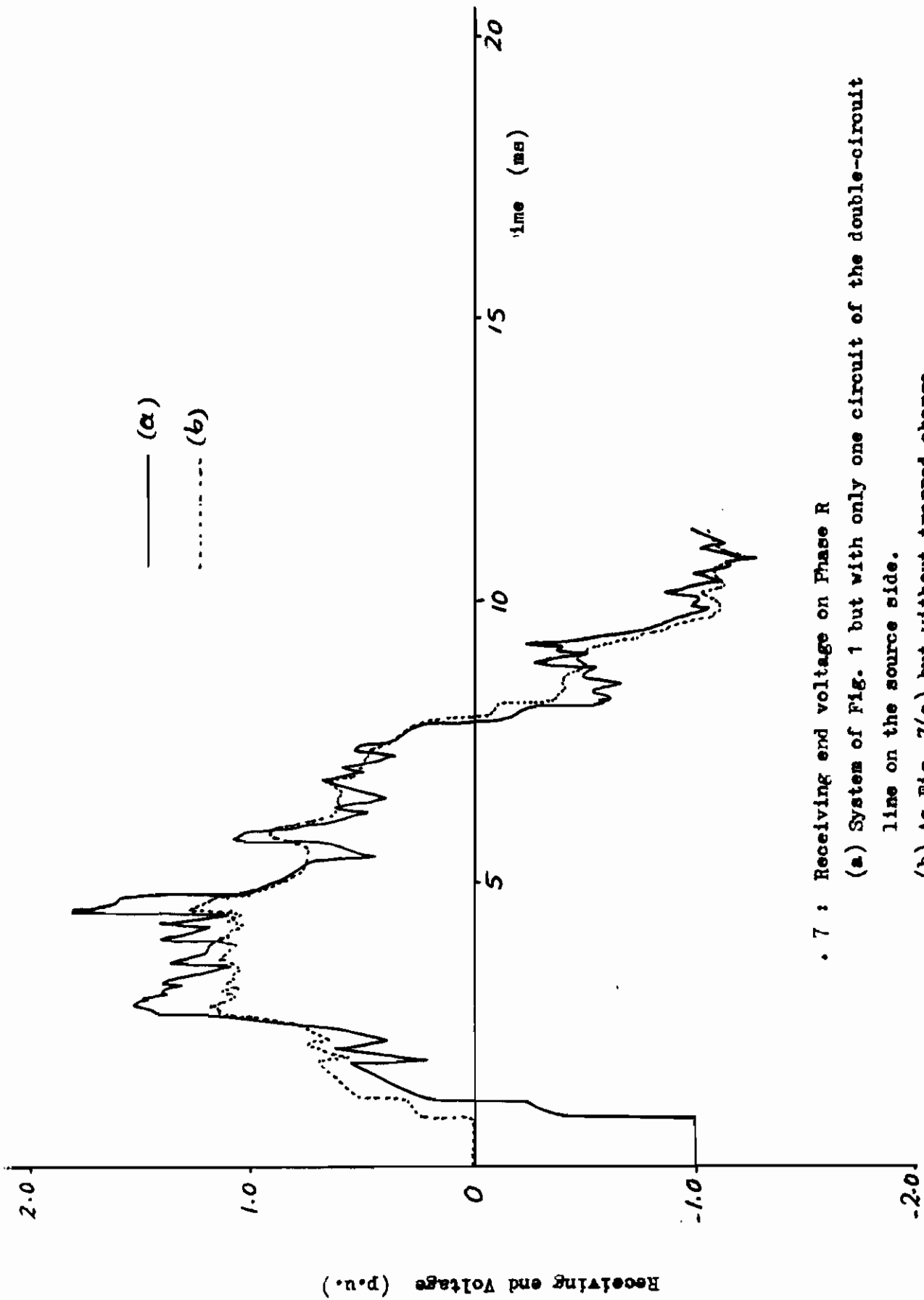

Fig. 6 : Receiving end voltage on Phase R with the system having no transmission lines on the source side.



. 7 : Receiving end voltage on Phase R

(a) System of Fig. 1 but with only one circuit of the double-circuit line on the source side.

(b) As Fig. 7(a) but without trapped charge.

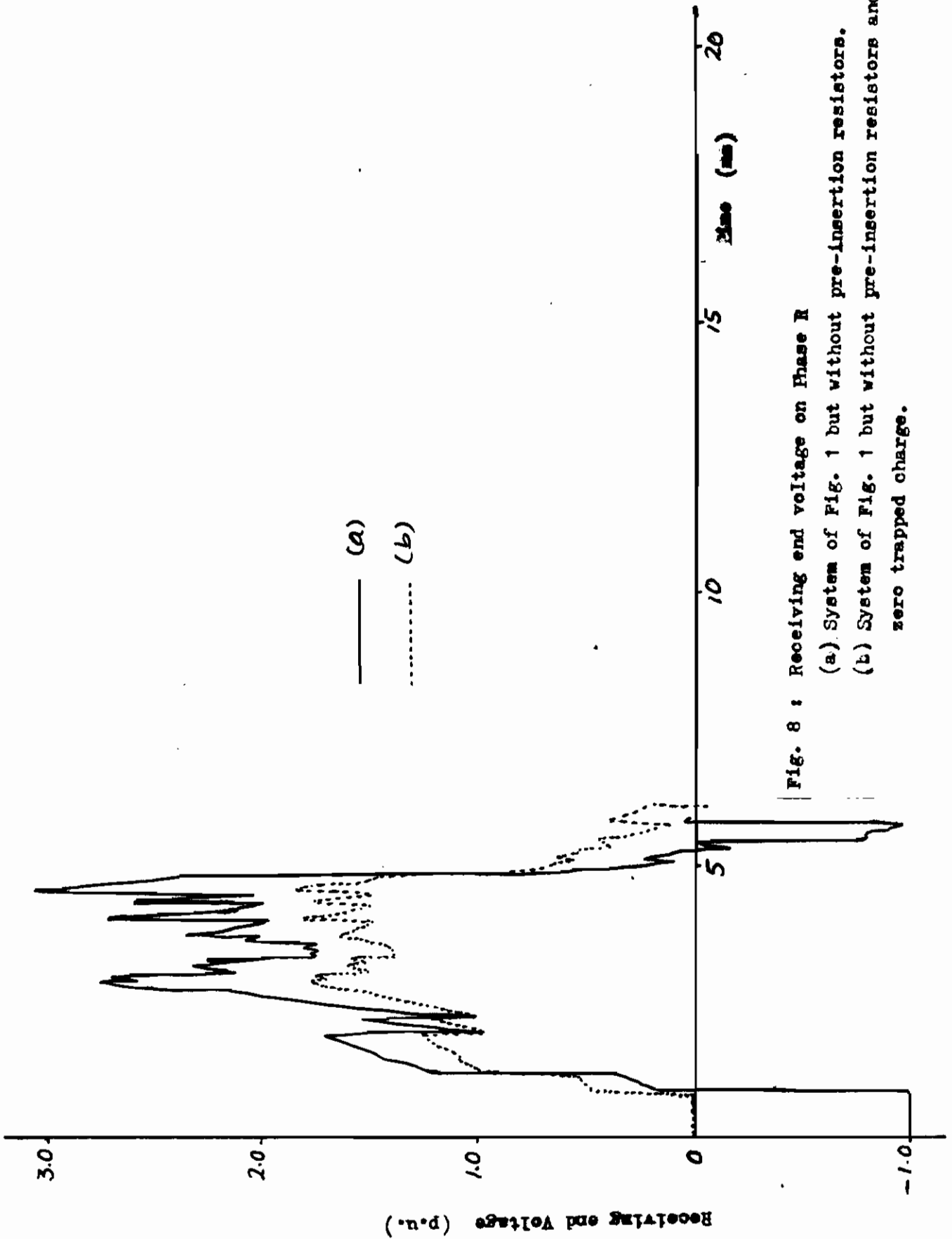

Fig. 8 : Receiving end voltage on Phase R

(a) System of Fig. 1 but without pre-insertion resistors.

(b) System of Fig. 1 but without pre-insertion resistors and with zero trapped charge.