

BIT ERROR RATE PERFORMANCE OF OFDM UTILISING DIFFERENTIALLY ENCODED 16 STAR QAM WITH DIFFERENTIALLY COHERENT DEMODULATION IN AWGN, FREQUENCY FLAT AND TWO-PATH FADING CHANNELS.

IBRAHIM. A. Z. QATAWNEH,
Electrical Engineering Department
Faculty of Engineering
Mutah University, AL-Karak, Jordan.

الاداء حسب معدل الخطأ لنظام التقسيم الترددي المضاعف المتعامد (OFDM) المستخدم لتشفير تفاضلي نوع 16 النجمي - بتضمين مقداري متعامد (QAM) وكاشف تفاضلي مترامن وقناة نقل ذات ضوضاء بيضاء مضافه كموصله التوزيع وقناة ذات تردد مسطح واخرى ذات خفوت بمسارين

الملخص:

ان تقنية الارسال ذو الترددات الحاملة المتعددة المعروف باسم التقسيم الترددي المضاعف المتعامد أستعمل في عقد الستينات (1960's) من القرن الماضي لغرض ارسال حزمة الصوت والبيانات.

اما الآن فهناك تطبيقان رئيسيان للتقسيم الترددي المضاعف المتعامد:

التطبيق الاول هو لدائرة المشترك الرقمية ذات السرعة العالية والتطبيق الثاني لاغراض البث الاذاعي للاشارات المسموعة والمرئية. وسوف نقدم هنا استخدامات التقسيم الترددي المضاعف المتعامد لتطبيقات اللاسلكي ذات معدل المعلومات العالي.

ولغرض تحسين كفاءة الطيف, أستخدم نظام التضمين المقداري المتعامد (16 QAM) ذو الستة عشر نجمة لتضمين الترددات الحاملة توازناً بدلاً من التضميني المتعامد QPSK المعتاد بأستخدام مفتاحية ازاحة الطور.

تتحرى هذه الورقة موضوع معدل الخطأ (BER) في المعلومات لنظام التقسيم الترددي المضاعف المتعامد الذي يستخدم مبدأ التضمين المقداري المتعامد (16 QAM) ذا الستة عشر نجمة وتشفير تفاضلي (DE)

ونظام كشف تزامني وقناة نقل مسطحة التردد وكذلك قناة نقل بمسارين وذات خفوت FADING ومبدأ كشف التضميني التفاضلي المتشابهه (منسجم الطور) في التردد وعندما تكون قنوات الارسال خالية من الخفوت او ذات خفوت.

استخدمت طريقة مونت كارلو في البحث لاغراض المحاكاة في تحليل النظام ودراسة خواصه المطلوبة.

اشتمل البحث ايضاً على مقارنة هذا النظام مع النظام التقليدي المكافئ الذي يعتمد التردد الحامل المنفرد.

التقسيم الترددي المضاعف المتعامد, القنوات ذات الخفوت, التضميني المقداري المتعامد النجمي, الاتصالات اللاسلكية والجوالة.

ABSTRACT

The multicarrier transmission technique known as Orthogonal Frequency Division Multiplexing (OFDM) was devised in the 1960's for voiceband data transmission. Today there are two principles FDM applications, one is for the high speed digital subscriber loop and the other is for the broadcasting of digital audio and video signals. It will consider the use of OFDM for high-bit rate wireless applications.

In order to improve spectral efficiency, 16 star quadrature amplitude modulation (QAM) is employed to modulate the parallel carriers in place of the usual quadrature phase shift keying (QPSK). This paper investigates the bit error rate (BER) performance of OFDM utilising differentially encoded (DE) 16 star QAM and differentially coherent demodulation

in frequency flat and two-path fading channels via Monte Carlo simulation. The BER performance of OFDM is also compared with equivalent single carrier systems.

Keywords - OFDM, fading channels, star QAM, wireless and mobile communications.

1. Introduction

The development of Orthogonal Frequency Division Multiplexing (OFDM) techniques [1,2] has allowed the transmission of high quality audio and digital television pictures to be demonstrated from both terrestrial and satellite based systems [3,4,5]. The aim of this paper is to investigate the use of OFDM for high bit rate wireless applications. In order to improve spectral efficiency, the use of differentially encoded (DE) 16 star quadrature amplitude modulation (QAM) is employed to modulate the parallel carriers [6]. OFDM is a wideband modulation scheme which is specifically designed to cope with the problems of multipath reception. It achieves this by transmitting a large number of narrowband digital signals over a wide bandwidth. The consequent longer symbol duration renders the system less susceptible to the effects of intersymbol interference (ISI) induced by a frequency selective channel. To achieve orthogonality, the sub-carrier frequencies are chosen to be spaced at the symbol rate, that is, if the OFDM symbol duration is T_s seconds, the sub-carrier frequency spacing is $1/T_s$ Hz [1].

2. System Simulation

A basic OFDM system can be simulated as shown in Figure 1. Firstly the data symbols from the DE 16 Star QAM modulator are converted from serial to parallel (S/P) format. In this simulation the output width of the converter is 16 symbols (complex valued) which corresponds with the number of parallel carriers in the OFDM signal at the output of the inverse Fourier transform (IFT) block. The output of IFT is the time domain OFDM signal which has 16 complex valued samples [7]. These samples are converted from parallel to serial format before being placed to the channel. In the receiver, the incoming signal is converted back to a parallel format before being processed by the Fourier transform (FT) which implements the demodulator. The FT output represents the parallel demodulated symbols which are converted back into the original serial format. These symbols are then differentially coherently demodulated to recover the data. In addition, in a number of simulations the S/P conversion process at the input to the IFT is more than a simple one to one mapping of the symbols from input to output. The data formats employed at the input to the IFT block will be described where required.

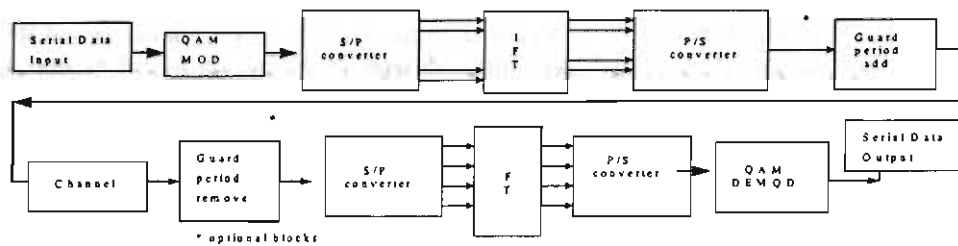

Figure 1. Basic OFDM system simulation model.

In the presence of intersymbol interference caused by the transmission channel, the properties of orthogonality between the carriers is no longer maintained. However, by preceding each symbol by a guard band it is possible to absorb the inter-symbol interference. This is achieved using the optional guard period block as shown in Figure 1. This guard period is removed at the receiver by the complementary guard period remove block. The guard period must be of limited duration [3], because although a longer guard period gives a more rugged system, it imposes a penalty because of the power required for its transmission. If Δ is the guard period, the duration of transmitted signal is given by $t_s = \Delta + T_s$, where T_s is the OFDM symbol period. In this case the guard period is created by taking the last four samples of the 16 time domain samples at the output of the IFT and then inserting them in front of the 16 original samples. Consequently, there are now 20 samples per OFDM symbol.

2.1 Differential 16 Star QAM

The majority of work concerning QAM for mobile radio applications has utilised square QAM constellations. In general 16 QAM (square) requires coherent detection. However, since the performance of coherent detection is severely affected by multipath fading, (mainly because of carrier recovery issues), the 16 Star QAM constellation shown in Figure 2 : combined with differentially coherent detection is preferred [6].

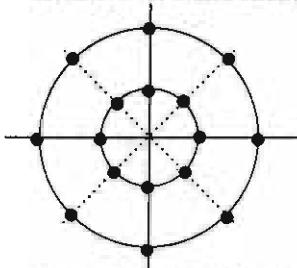

Figure 2. 16 level star QAM constellation.

2.1.1 Modulator

The modulator structure for 16 Star QAM is shown in Figure 3. The random data source gives a binary sequence, which is formed into four bit symbols namely, a_n, b_n, c_n, d_n . The carrier is differentially phase modulated by the last three bit, b_n, c_n, d_n and differentially amplitude modulated by the first bit a_n . The first bit a_n is used to determine the transmitted signal amplitude as follows. If the incoming bit a_n is a binary '1' the amplitude level of the transmitted signal is changed to the other amplitude level. However, if the incoming bit a_n is

a binary '0' the amplitude level of the transmitted signal remains the same as shown in Table 1. The remaining three bits, b_n, c_n, d_n are Gray encoded to give the phase changes shown in Table 2. Consequently it can be seen that a differential 16 star QAM is a combination of independent 8DPSK and 2DASK.

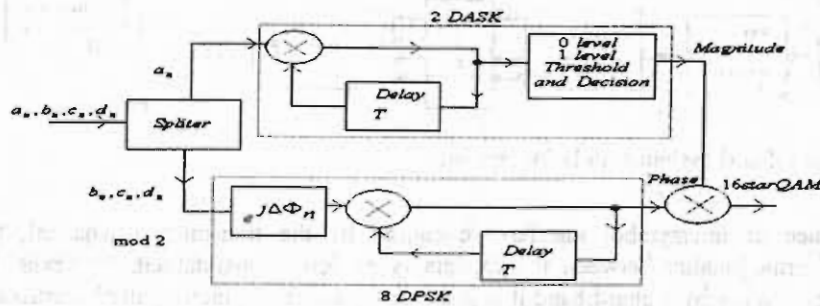

Figure 3. Modulator structure for 16 Star QAM.

For example, suppose that the current input bits $\{b_n, c_n, d_n\}$ are "000" and the previous transmitted phase is 0° , it can be seen from Table 2 that the required phase change is zero degrees giving a transmitted phase of 0° .

Information symbol, a_n	Amplitude change
0	No
1	Yes

Table 1. Amplitude bit change

information bits b_n, c_n, d_n	phase change (degrees)
000	0
001	45
011	90
111	135
101	180
100	225
110	270
010	315

Table 2. 16 Star QAM phase change.

2.1.2. Differential Coherent Demodulator

The differential detection of a 16-star QAM signal can be split into two parts: first the differential phase detector for the 8 PSK signal and second the differential detection of the two level amplitude modulated signal. Suppose the amplitude levels of the transmitted signal are L_1 and L_2 . Now suppose the received phasor amplitudes at time T_n and T_{n+1} are $|Z_n|$ and $|Z_{n+1}|$ respectively. The function of the differential amplitude demodulator is to identify any significant change of the received amplitude which may indicate the transmission of a binary '1'. The decision circuit shown in Figure 4 employs two adaptive thresholds to make this decision according to the following rules [6]

$$|Z_{n+1}| \geq \left(\frac{L_1 + L_2}{2}\right) |Z_n| \quad (1)$$

or if

$$|Z_{n+1}| < \left(\frac{2}{L_1 + L_2}\right) |Z_n| \quad (2)$$

In this system, $L_1 = 1$, and $L_2 = 3$, consequently Equation 1 becomes,

$$|Z_{n+1}| \geq 2|Z_n| \quad (3)$$

and Equation 2 becomes

$$|Z_{n+1}| < 0.5|Z_n| \quad (4)$$

The decision block implemented in Figure 4 consists of two comparators, the upper comparator implements Equation 3 while the lower comparator implements Equation 4. The outputs of the two comparators are fed to an OR-gate to combine their decisions as shown in Table 3

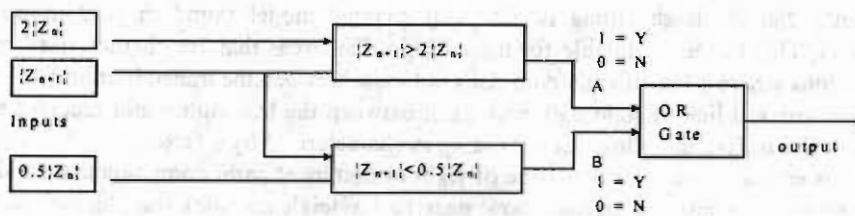

Figure 4. Decision block diagram.

A	B	Output
0	0	0
0	1	1
1	0	1
1	1	*

* means a do not care condition (as this input combination cannot occur).

Table 3. Magnitude bit decision.

Now the decoder have to decode the differential phase signal. Suppose the received symbol phases are β_n and β_{n+1} at times T_n and T_{n+1} respectively. It must calculate the phase difference $\Delta\beta_n$ between these two phases to estimate the transmitted symbol. To do this the current input sample Z_{n+1} is multiplied by the complex conjugate of the previous sample Z_n as shown in Figure 5. The argument of this complex valued result yields the phase difference $\Delta\beta_n$. This phase difference is then mapped to the corresponding 3-bit output using the 8PSK slicer. The resulting binary data from the magnitude and phase decisions are merged to give the final serial output data.

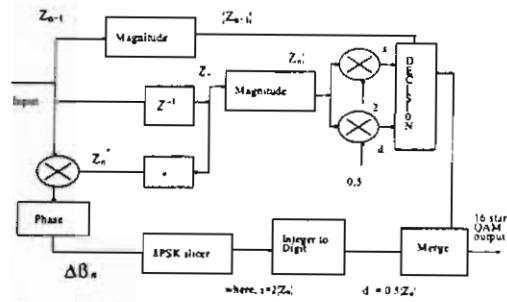

Figure 5. DE 16 Star QAM decoder

2.2 Fading Channel Simulation Models

Because communication engineers are interested in mobile and wireless applications then the appropriate radio channel models must be utilized in the simulations.

2.2.1 Flat Rayleigh Fading

Frequency flat Rayleigh fading is a typical channel model found in land mobile radio situations. This model is suitable for modelling urban areas that are characterised by many obstructions where a line of sight path does not exist between the transmitter and receiver. In suburban areas, a line of sight path may exist between the transmitter and receiver and this will give rise to Rician fading. Rician fading is characterised by a factor, which is expressed as the power ratio of the specular (line of sight or dominant path) component to the diffused components. This ratio, a , defines how near to Rayleigh statistics the channel is. In fact when $a = 0$, this means to have Rayleigh fading, and there is no fading at all when $a = \infty$. Figure 6 shows the simulation block diagram.

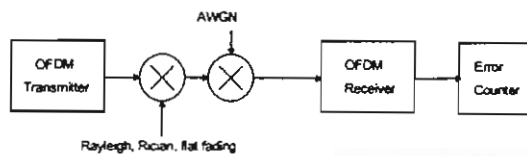

Figure 6. OFDM system and channel.

The rate of change of the fading is defined by the Doppler rate. To enable comparison between systems we define a normalised Doppler rate given by, $f_{dn} = f_d T_s$, where f_d is the maximum Doppler rate and T_s is the transmitted symbol duration.

2.2.2 Frequency Selective Fading

A propagation model applicable for higher rate systems includes many discrete scatters, where each propagation path may have a different amplitude, propagation delay and

Doppler shift.

Consequently the transmitted signal will experience a channel with a non-flat frequency response, which also varies with time. This type of channel is said to be frequency selective and is usually modelled as a tapped delay line, where the number of taps is equal to the number of discrete delayed paths. Clearly, the effect of the tapped delay line is to introduce overlap between the transmitted symbols giving rise to intersymbol interference (ISI). One simple frequency selective channel model is the two path fading channel shown in Figure 7.

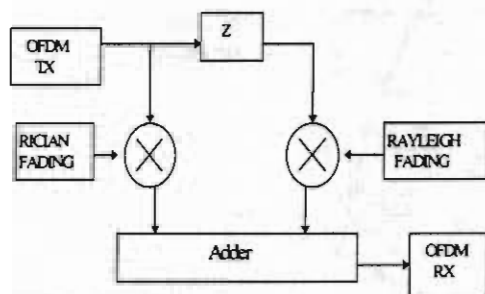

Figure 7. Two Path Channel Model

In this model the first arriving path experiences Rician fading and the second arriving path (which has a delay set by the delay parameter, z) experiences Rayleigh fading. In addition, to define a ratio (d) between the power in the first path (Rician fading) and the power in the second path. Which is called d In this work, $d = 15$, and the ratio a for the first fading path is equal to 15 for all the simulations.

3. Results and Discussion

3.1 Performance of OFDM/ Differential Encoded (DE) 16 Star QAM in AWGN

In this section the BER performance of OFDM/ DE 16 Star QAM with a guard period and single carrier DE 16 Star QAM disturbed by AWGN are compared. Figure 8 shows the BER results as a function of signal to noise ratio (SNR) for both a single carrier and for an OFDM system using differential 16 star QAM encoding. Clearly the BER performances are identical in AWGN.

3.2 Performance of OFDM/DE 16 Star QAM in the First Fading Channel

The BER performances presented in Figure 9 compare single channel and OFDM systems using DE 16 star QAM in the Gaussian channel ($a=\infty$) and a specular Rician channel ($a=15$) with a normalised Doppler rate of 0.1. It can be observed that the Rician channel degrades the SNR performance of the OFDM systems by about 6 dB compared with that achieved over the Gaussian channel at a BER of 0.001. The single channel system performance is some 3 dB worse than the OFDM system at the same BER in the Rician channel. The

irreducible BER is also higher for the single channel system. This is because the OFDM system sends 16 QAM symbols in the time taken for the single channel system to send one. Consequently Doppler induced phase changes are less of a problem in this case.

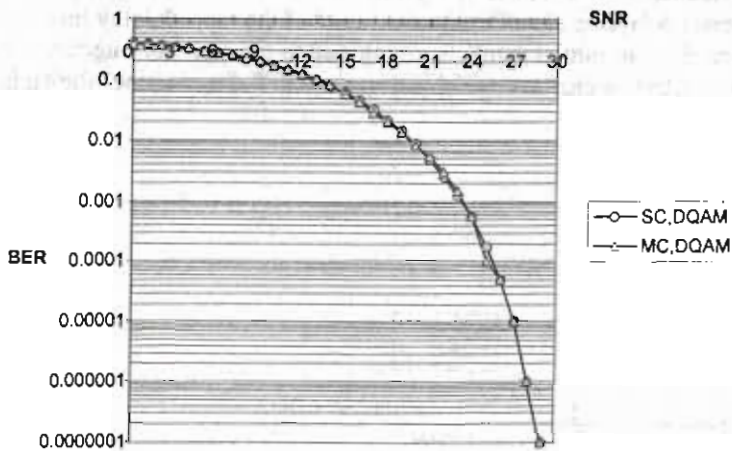

Figure 8. OFDM/DE 16 star QAM and single DE 16 star QAM in AWGN.

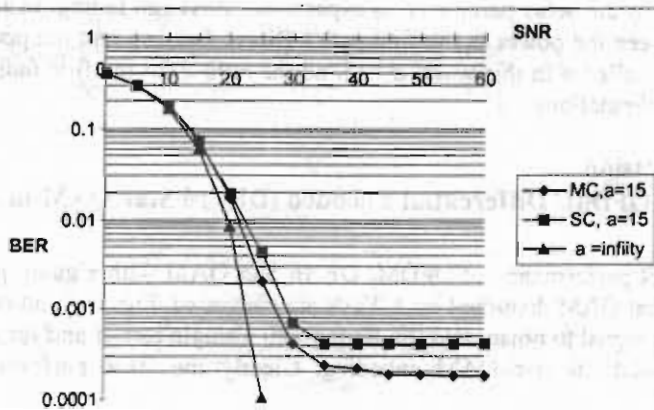

Figure 9. Comparison of DE 16 star QAM, used in both single carrier and OFDM systems in the presence of AWGN and first fading path (Rician fading), $a=15$.

The simulation results presented in Figure 10 show the performance OFDM/DE 16 star QAM with differentially coherent demodulation, in the presence of AWGN for various values of the Rician fading power ratio (a) and a normalised Doppler rate of 0.1. It can be seen that the BERs become irreducible for all the simulated values of a except for the

AWGN case of $a=\infty$. That said, for the specular Rician channel $a=15$, the BER results are only some 5 dB worse than the AWGN case at a BER of 0.001. The irreducible BER is about 1×10^{-4} for this situation which could be reduced by the use of forward error correction.

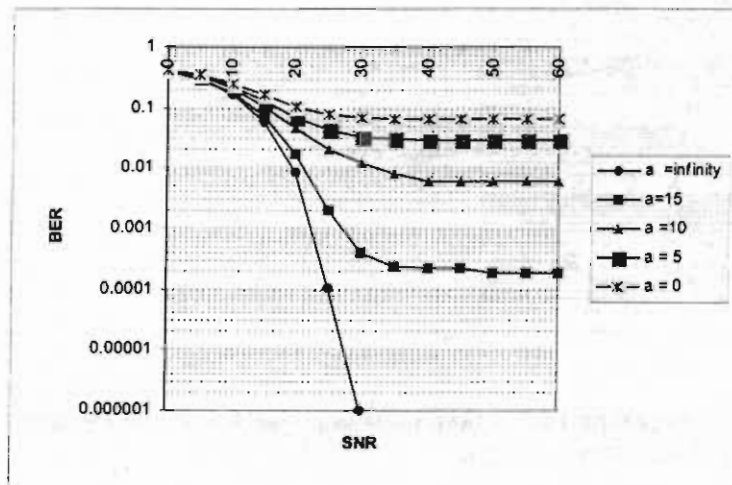

Figure 10. BER performance of OFDM/DE 16 star QAM in the presence of AWGN with various Rician fading channels and a Doppler rate of 0.1 Hz.

For the next set of results, choose to multiplex a single DE 16 star QAM source on to one of the sixteen OFDM channels and pad the remaining channels with suitable data. The simulation BER results are shown in Figure 11 for various first channels (Rician channels). It can be observed that these results are slightly worse than those shown in Figure 10 which corresponds with the previous multiplexing scenario. This is because the symbols from the independent source are subject to larger channel induced phase changes than those experienced by the scenario relevant to Figure 10. Clearly in this situation there is no advantage in using this multiplexing arrangement.

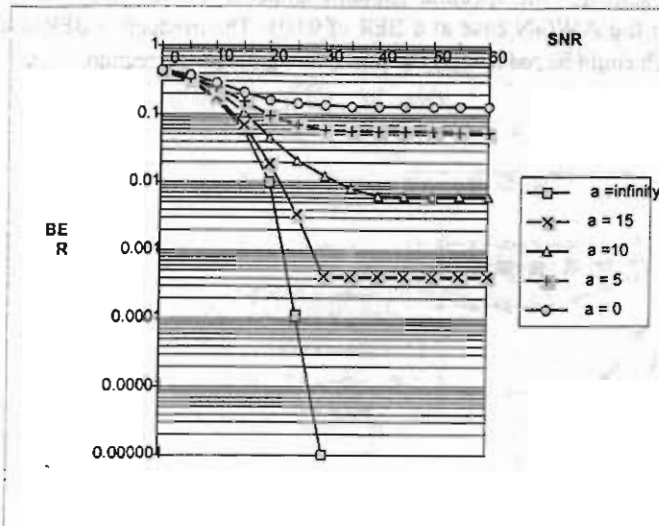

Figure 11. Performance of OFDM/DE 16 star QAM, single source per channel multiplexing in AWGN with first fading channel (Rician fading).

3.3 Results for Two-Path Fading Channel

The simulation results shown in Figure 12 give the BER performance for OFDM/DE 16 star QAM in the presence of AWGN with two-path fading for various values of second path delay. All the results are taken for the system in the presence of AWGN, a first arriving Rician channel with a fading power ratio $a=15$, a first path to second path power ratio of $d=15$, and a normalised Doppler rate 0.1. Clearly when the second path delay is greater than the guard period of four samples, e.g., $z = -6$, the BER performance is very poor. The irreducible BER falls in excess of one order of magnitude to 6×10^{-3} when the delay between first and second paths is reduced from four samples to one sample. Even so, this level of irreducible BER is excessive for most applications and further measures such as forward error correction are necessary in this situation.

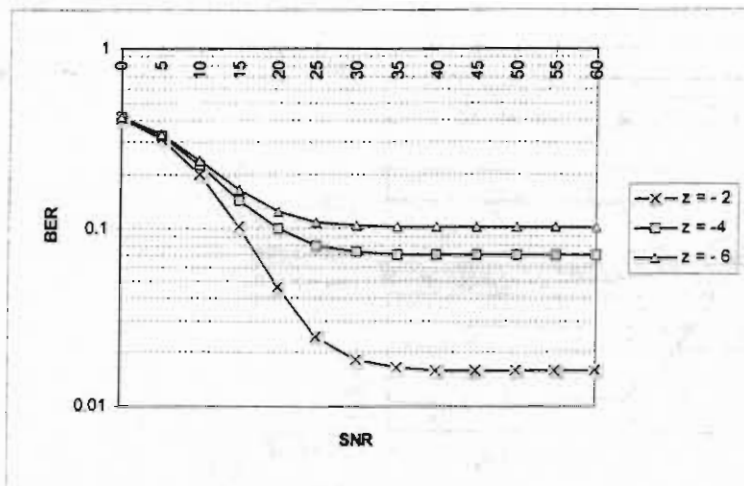

Figure 12. BER performance for OFDM/DE 16 star QAM in the presence of AWGN with two-path fading (second fading channel).

Figure 13 shows the BER results for OFDM/DE 16 star QAM with single source per channel multiplexing in a two-path channel with various values of delay.

4. Conclusion

In this paper, the performance of OFDM/DE 16 star QAM has been investigated in AWGN, flat Rayleigh/Rician fading and two-path fading channels.

With a specular ($\alpha=15$) Rician channel at a normalised Doppler rate of 0.1, the degradation from AWGN performance at a BER of 0.001 is only 5 dB, though a Rayleigh channel ($\alpha=0$) gives rise to an unacceptable irreducible BER of about 0.01. However, for the indoor or microcellular environment a direct path is likely to lead to less hostile channels than flat Rayleigh fading. With two-path fading and a normalised Doppler rate of 0.1, the BER performance is not acceptable, even at low values of second path delay. However, in the indoor or microcellular channel, the normalised Doppler rate is likely to be lower than the 0.1 used in the simulations. This will improve the performance of the differentially coherent demodulator, especially for single source per channel multiplexing.

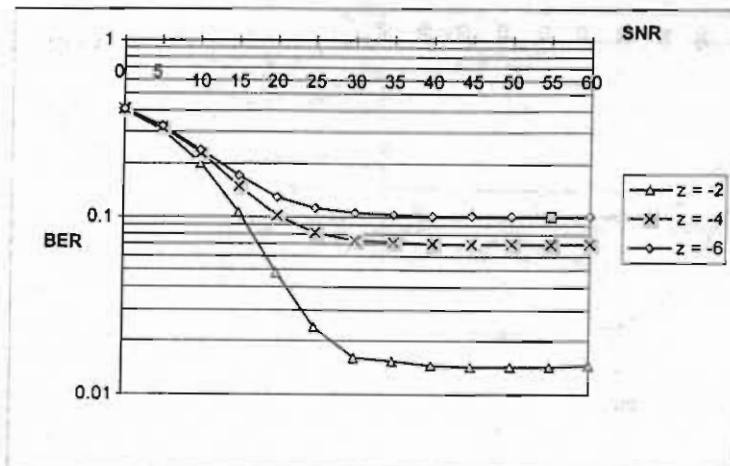

Figure 13. BER performance for OFDM/DE 16 star QAM with single source per channel multiplexing in the presence of AWGN and two-path fading second fading channel).

When compared with the results for the previous multiplexing arrangements shown in Figure 12, it can be seen that single source per channel multiplexing gives a slightly worse BER performance.

References

- [1] R. W.Chang, "Synthesis of Band-limited Orthogonal Signals for Multichannel Data Transmission," Bell System. Tech. J., Vol. 45, pp. 1775-1796, Dec. 1966.
- [2] R.W. Chang and R A. Gibby, " Orthogonal Multiplexed Data Transmission," IEEE Transactions on Communication Technology, Vol.18, pp. 530 - 540, August 1968.
- [3] P. Shelswell, " The COFDM Modulation System : the Heart of Digital Audio Broadcasting," Electronics & Communication Engineering Journal, June 1995.
- [4] H. Sari et. al., "Transmission Techniques for Digital Terrestrial TV Broadcasting," IEEE Communications Magazine, Feb. 1995, pp. 100-109.
- [5] M. Carrasco, A. Lange, " What markets for DAB in Western Europe," First International Symposium on DAB-92.
- [6] W.T. Webb, L. Hanzo, and R. Steele. "Bandwidth efficient QAM schemes for Rayleigh fading channels," IEE Proceedings-I, Vol.138, No.3, pp. 168-175, June 1991.
- [7] S. B. Weinstein, "Data Transmission by Frequency Division Multiplexing using the Discrete Fourier Transform," IEEE Transactions on Communication Technology, Vol. Com -19, No. 5, October 1971.